

- Robust aluminium enclosure with 4, 6 or 8 flange openings
- Prepared for the installation of DIN rails

Included in delivery

Aluminium enclosures consisting of lid, seal, incl. captive +/- stainless steel screws, base with 2 or 4 earthing screws.

Flange plates are not included in the scope of delivery, they have to be ordered separately.

Technical data

Material:

DIN EN 1706 EN AC-AISI 12 (Fe)

Painting:

powder coating

Colour:

RAL 7001, silver grey

special colour on request

Ingress protection:

IP 65 to EN 60529

Impact resistance:

7 Joule to EN 60079-0

Temperature range:

PU (polyurethane) seal (std.): -40°C to +90°C

CR (chloroprene) seal: -40°C to +100°C

VMQ (silicone) seal (optional): -60°C to +130°C

Accessories



Blind flange
undrilled with round seal

Order No. **10.00 60 01**



Flange with drill holes
(PG and metric) on request



Flange with cut-out for heavy industrial connectors

Order No.	cut-out for
10.00 60 06	HAN 6B or compatible
10.00 60 16	HAN 16B or compatible
10.00 60 24	HAN 24B or compatible

For further accessories please refer to the Aluminium-Standard range

Type: **11.23 40 11**

External dimensions: **230 x 400 x 111 mm**

Weight: **4600 g**

DIN rail length in mm	max. fitting length in mm	Earthing rail clamp	Mounting plate (thickness in mm)	External mounting brackets	External hinge* set	EMC version	Internal hinge* set	SWB / SBGL Corr.protection	Allen lid screws	Silicone lid seal	Sealable lid screws in steel	Turn bolt fastener on request	Quick lock
TS 35	335	25		•				•	•	•	•		

Maximum number of cable glands to *DIN 50262**

M	Corner dim.	Side		PG	Corner dim.	Side	
		A/B	C/D			A/B	C/D
12	17.25	246	162	7	17.25	246	162
16	25.30	126	72	9	21.85	160	99
20	27.60	100	68	11	25.30	112	72
25	37.95	54	33	13.5	27.60	100	64
32	48.30	30	20	16	31.05	77	53
40	60.95	18	12	21	37.95	54	33
50	69.00	15	9	29	48.30	30	20
63	74.75	12	8	36	60.95	18	12
				42	69.00	15	9
				48	74.75	14	8

Lid

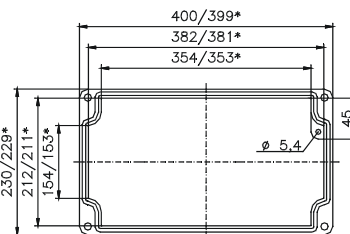

* = Conical form tapering downwards
Free dimensions-tolerance to GTA 13/5 DIN 1688

Base

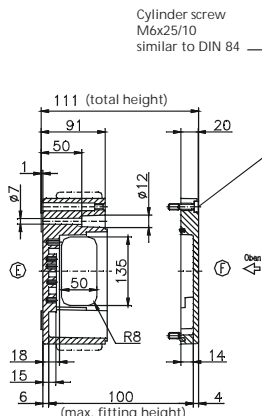
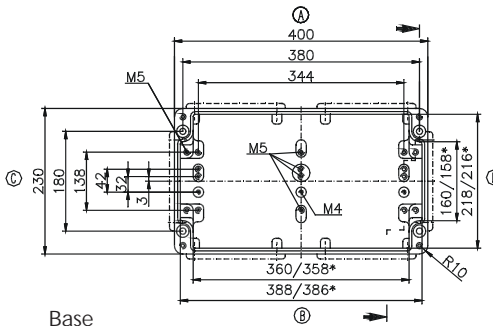

Type: **11.23 60 11**

External dimensions: **230 x 600 x 111 mm**

Weight: **6100 g**

DIN rail length in mm	max. fitting length in mm	Earthing rail clamp	Mounting plate (thickness in mm)	External mounting brackets	External hinge* set	EMC version	Internal hinge* set	SWB / SBGL Corr.protection	Allen lid screws	Silicone lid seal	Sealable lid screws in steel	Turn bolt fastener on request	Quick lock
TS 35	535	40		•				•	•	•	•		

Maximum number of cable glands to *DIN 50262**

M	Corner dim.	Side		PG	Corner dim.	Side	
		A/B	C/D			A/B	C/D
12	17.25	150	68	7	17.25	150	68
16	25.30	76	28	9	21.85	96	42
20	27.60	60	24	11	25.30	72	27
25	37.95	30	12	13.5	27.60	60	24
32	48.30	20	7	16	31.05	48	18
40	60.95	10	4	21	37.95	28	12
50	69.00	8	3	29	48.30	20	6
63	74.75	6	3	36	60.95	10	4
				42	69.00	8	3
				48	74.75	6	3

Lid

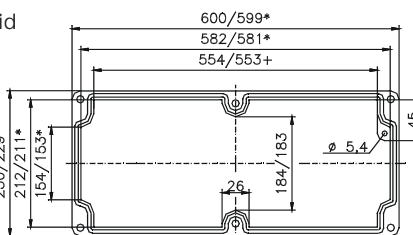

* = Conical form tapering downwards
Free dimensions-tolerance to GTA 13/5 DIN 1688

Base

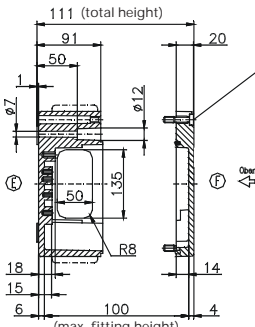
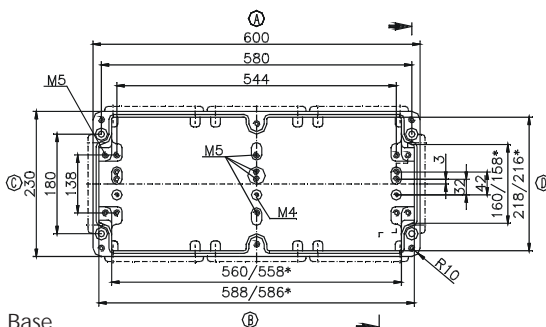

* Please quote mounting side