



Wireless DC multi-channel PWM dimmer

WPD-06



■ Features :

- Easy configuration & installation
- 6 protected output channels
- Independent dimming control on each channel
- Up to 128 wireless batteryless switches connected possible
- Built-in wire push dimming function*
- Suitable for constant voltage lighting application
- Possible for constant current lighting application(optional)
- Multiple dimmer application via CANBus possible(optional)
- Up to 30 meter wireless distance
- Conformal coating for harsh and high humidity environment
- 5 year warranty

■ Description :

WPD-06 is a wireless dimming device for 12/24V LED strips working with batteryless switches with mounting plate which can be perfectly fitted into the wall for standard household application. No more dimming wires need to be installed.

■ Benefits:

- Powered by any DC source between 10-32 VDC
- Work with EnOcean switches with no battery required
- Work with EnOcean switches with no maintenance required
- Standard wall mounting form factor for switches
- Cost saving solution due to no physical wires between dimmer and switch
- Excellent dimming experience compared to traditional AC mains dimming
- Possible for constant current lighting application(optional)
- Suitable for 2-way dimming switching home application e.g. staircase lighting



SPECIFICATION

MODEL		WPD-06
OUTPUT	DC VOLTAGE	Depending on input voltage
	RATED CURRENT	4,5A each channel ~ 27A for the entire module
	RATED POWER	324W (input : 12V) ; 648W (input : 24V)
	OUTPUT CHANNEL	6
	DIMMING RANGE	1 to 100% ; Switching frequency : 125 Hz
	TERMINAL	Clamping Spring disconnectable terminal for solid or stranded copper conductors 0,25 to 2,5mm ²
INPUT	VOLTAGE RANGE	10~ 32VDC SELV
	DC CURRENT	27A
	STANDBY POWER	1.2W(Typ.)
	TERMINAL	Clamping Spring disconnectable terminal for solid or stranded copper conductors 0,25 to 2,5mm ²
PROTECTION	OVERLOAD	150% rated output power for 300ms max. Protection type : Electronic shut down rated at 5A. Restart by switching On again the output of channel
	OVERVOLTAGE	Transient protection starting at 33V
FUNCTION	WIRELESS CONTROL	Use EnOcean wireless batteryless switches or actuators
	WIRELESS DISTANCE	30 meter(Typ.)
	FREQUENCY OPERATION	868MHz (other frequency for outside EU available on request)
	WIRE CONTROL	3 independent Push dimming port
EMVIRONMENT	WORKING TEMP.	-40 ~ +60°C
	WORKING HUMIDITY	20 ~ 90% RH non-condensing
	STORAGE TEMP., HUMIDITY	-40 ~ +85°C, 10 ~ 95% RH
SAFETY & EMC	VIBRATION	10-500Hz, 2G 10min./1cycle, 60min. each along X, Y, Z axes
	SAFETY STANDARDS	Design refer to EN61347-1, 61347-2-13, 61347-2-11
	EMC EMISSION	Compliance to EN55015, ETSI EN300220-1, 300220-2, 301489-1, 401489-3
OTHERS	EMC IMMUNITY	Compliance to EN61547
	MTBF	50 Khrs min.
	DIMENSION	110*77*26.4 mm (L*W*H)- Weight 0,120Kg
NOTE	1. Do not wire push dimming inputs with an external voltage, especially not a mains voltage of 230 V .	

■ World Coverage Map

COUNTRY/REGION	STANDARD	FREQUENCY
Aruba	Possibly R&TTE Directive	868 MHz – Confirm with test house
Australia / New Zealand	N.A.	
Barbados	N.A.	Note1
Bermuda	N.A.	Note1
Bolivia	N.A.	Note1
Brazil	ANATEL	868 MHz
British Virgin Islands	N.A.	Note1
Cayman Islands	Possibly R&TTE Directive	868 MHz
CEPT (European regional)*	EN 300 220	868 MHz
Chile	Possibly R&TTE Directive	868 MHz
China	CNAS/MIIT EN 300 220	868 MHz
Colombia	Possibly ANATEL	868 MHz
Ecuador	N.A.	Note1
El Salvador	Possibly R&TTE Directive	868 MHz
French Guiana	ETSI EN 300 220	868 MHz
Guatemala	N.A.	Note1
Hong Kong	Possibly 315MHz	Note1
India	Possibly 315MHz	Note1
Israel	Possibly 315MHz	Note1
Jamaica	N.A.	Note1
Japan 920**	ARIB STD-T108	928MHz
Malaysia	SKMM WTS SRD/ EN 300 220	868 MHz
Mexico	We believe Mexico does not accept FCC	868 MHz
Nicaragua	N.A.	Note1
Peru	N.A.	Note1
Panama	FCC CFR47 Part 15.249	902 MHz
Russia	N.A.	
Singapore	TS SRD/ EN 300 220	868 MHz
South Africa	ICASA/ EN 300 220	868 MHz
South Korea	N.A.	
Suriname	N.A.	Note1
Taiwan	Possibly 315MHz	Note1
Trinidad & Tabago	N.A.	Note1
Turks & Caicos Islands	Possibly R&TTE Directive	868 MHz
UAE	EN 300 220	868 MHz
Uruguay	N.A.	Note1
USA/Canada	FCC CFR47 Part 15.249	315MHz, 902 MHz

Note1: It is suggested to check with local accredited certification agency.

*CEPT is the European regional organization dealing with postal and telecommunications issues and presently has 45 Members: Albania, Andorra, Austria, Azerbaijan, Belarus, Belgium, Bosnia and Herzegovina, Bulgaria, Croatia, Cyprus, Czech Republic, Denmark, Estonia, Finland, France, Germany, Greece, Hungary, Iceland, Ireland, Italy, Latvia, Liechtenstein, Lithuania, Luxembourg, Malta, Moldova, Monaco, Netherlands, Norway, Poland, Portugal, Romania, Russian Federation, San Marino, Serbia and Montenegro, Slovakia, Slovenia, Spain, Sweden, Switzerland, The former Yugoslav Republic of Macedonia, Turkey, Ukraine, United Kingdom, and Vatican.

**In February 2012, Japanese regulatory body ARIB (Association of Radio Industries and Businesses) released new 920 MHz frequency band for radio equipment, due to LTE rollout. The 950 MHz frequency band will be obsolete by end of 2015.



Wireless DC multi-channel PWM dimmer

WPD-06

Mechanical Specification

Case No. WPD-06 Unit:mm

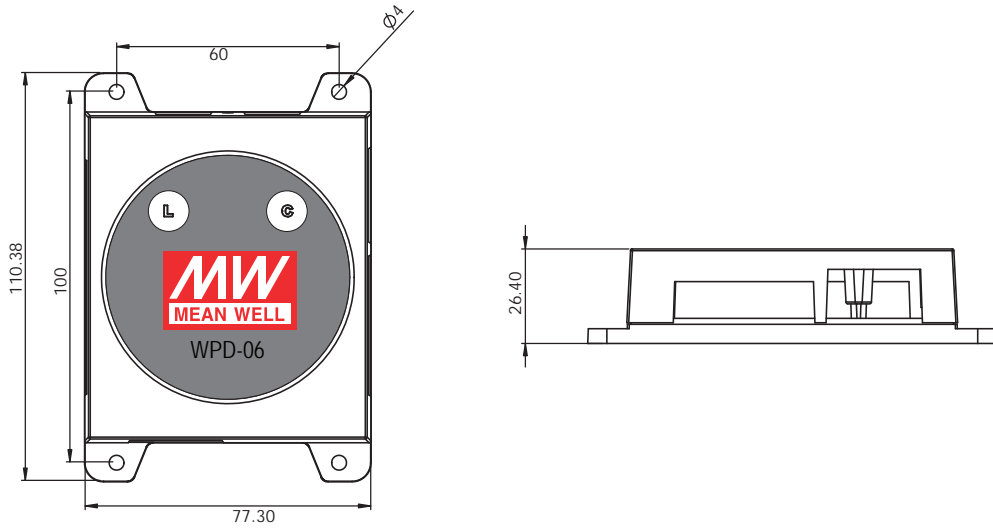

Block Diagram

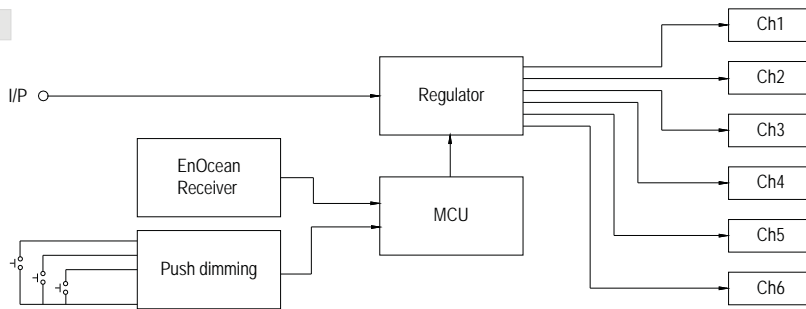

Interoperable products / EnOcean Equipment Profile(EEP)

Manufacturer	Telegram
Rocker Pad Switch	RPS(F6-02-03)
Contacts and switches	1BS(D5-00-01)
Occupancy Sensor	4BS(A5-07-01; A5-07-02; A5-07-03)
Light, Temperature and Occupancy Sensor	4BS(A5-08-01; A5-08-02; A5-08-03)
Light Sensor *	4BS(A5-06-01; A5-06-02; A5-06-03)

*: It will be supported soon

Batteryless wireless switch supplier

Manufacturer	Model*
Legrand	0 784 42
Siemens	5WG4222-3AB10
Berker	24121009
Jung	ENO A 595
Busch-jaeger	EASYSENS/ ENOCEAN
Gira	2422 03
Peha	D 455/61.022 FU-BLS N
Eltako	F4T65
VIMAR	20505+20506.B+21507.B

*: The model list is provided for reference. For more information please contact original supplier

■ Connector description

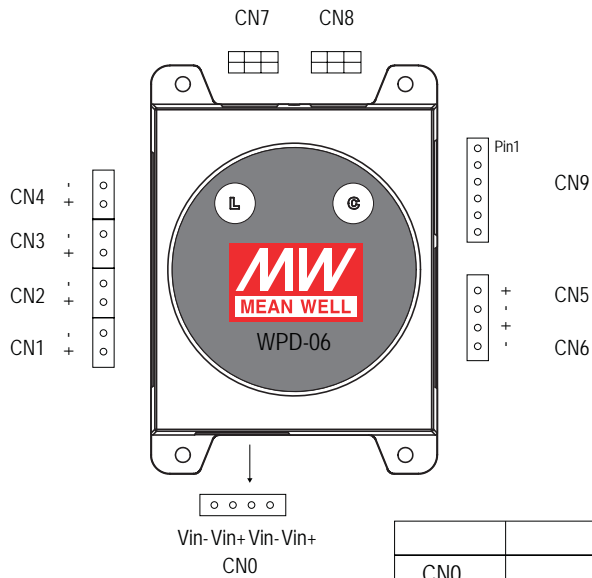

CN9: Push dimming and other control Pin No. assignment

Pin No.	Function
1	Optional coding plug
2	Ground
3	Bypass input(default open)
4	Push dimming
5	Push dimming
6	Push dimming

	Function	Matting connector	Wire thickness
CN0	Vin	WAGO - 2092-1104/002-000 or 2092-1102/002-000 x 2	0.2-2.5mm ²
CN1	Vout_channel1	WAGO - 2092-1102/002-000	0.2-2.5mm ²
CN2	Vout_channel2	WAGO - 2092-1102/002-000	0.2-2.5mm ²
CN3	Vout_channel3	WAGO - 2092-1102/002-000	0.2-2.5mm ²
CN4	Vout_channel4	WAGO - 2092-1102/002-000	0.2-2.5mm ²
CN5	Vout_channel5	WAGO - 2092-1102/002-000	0.2-2.5mm ²
CN6	Vout_channel6	WAGO - 2092-1102/002-000	0.2-2.5mm ²
CN7	N.C.		
CN8	N.C.		
CN9	Push dimming and other control	WAGO - 2091-1106/002-000	0.2-1.5mm ²

■ Dimmer button description

L (Learn) Button:

Pressing on this button enter the pairing mode. This is indicated by the first output blinking. Press L button again will jump to the next channel to pair and allow leaving the pairing mode after the seventh(7) press.

If no other action follow the first press, the dimmer come back to its normal mode after two minutes.

C (Clear) Button:

In pairing mode, a long press (1.5sec) on the C button erases the pairing of the blinking output.

In normal mode, a long press (1.5sec) on the C button erases the 6 outputs of the dimmer and it will automatically enter the pairing mode on Channel 1. Press L button 6 times to exit the pairing mode.

Remark: It is also possible to erase one switch from one channel (without erasing the other wireless batteryless switches paired on this output)



Wireless DC multi-channel PWM dimmer

WPD-06

Installation & Pairing

1. Connect a 10-32V DC power/driver to CN0 using plug.
2. Connect at least one LED strip lamp to any channel using plug.

The following steps is assumed that one LED strip lamp connected to Channel 1 (CN1):

- 1) Long press L button on dimmer and LED connected to Channel 1 is now blinking. It means now Channel 1 is at pairing mode.
- 2) Press on wireless batteryless switch to pair it. First press on switch is set to turn on Channel1. Second press on switch is set to turn off Channel1. The LED is blinking again.
Now this wireless batteryless switch is paired with Channel 1. In case there is another switch needs to be paired, re-do the step 2).
- 3) Press L button on dimmer. The pairing is now moving to Channel 2. Any LED connected to Channel 2 is now blinking.
- 4) Press L button on dimmer. The pairing is now moving to Channel 3. Any LED connected to Channel 3 is now blinking.
- 5) Press L button on dimmer. The pairing is now moving to Channel 4. Any LED connected to Channel 4 is now blinking.
- 6) Press L button on dimmer. The pairing is now moving to Channel 5. Any LED connected to Channel 5 is now blinking.
- 7) Press L button on dimmer. The pairing is now moving to Channel 6. Any LED connected to Channel 6 is now blinking.
- 8) Press L button on dimmer to finish the pairing.
- 9) Now the system is set and ready to control the LED lamp on channel 1.

Dimming function:

Press the wireless batteryless switch to turn on the LED.
Press again and hold it till the light is dimmed to the level as request.
Release the switch.

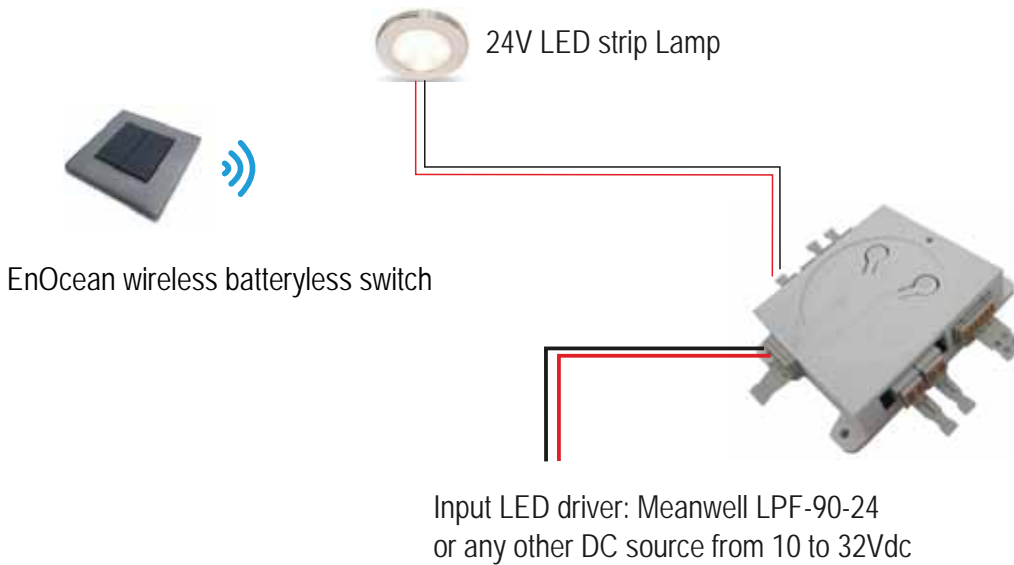

Demo Kit

Order code: WPD-06KIT

It contains the following:

	Item	code	Quantity
1)	WPD-06 dimmer	WPD-06	1
2)	EnOcean wireless batteryless 2 Key (4 switches)	WPD-06SWT	1
3)	WAGO - 2092-1102/002-000 plug	WPD-06CON	8



EnOcean wireless batteryless 2 Key (4 switches); Code:WPD-06SWT

Note: It is possible to order the plug and switch separately.

■ Push dimming pairing

There are three independent Push dimming port in WPD-06.

1. Connect a 10-32V DC power/driver to CNO using plug.
2. Connect at least one LED strip lamp to any channel using plug.
3. Connect a Push button between any Pin 4 or 5 or 6 and Pin 2(Ground) of CN9.

The following steps is assumed that one LED strip lamp connected to Channel 1 (CN1) and Push button between Pin 6 and Pin 2:

- 1) Long press L button on dimmer and LED connected to Channel 1 is now blinking. It means now Channel 1 is at pairing mode.
- 2) Press on Push button to pair it. First press on Push button is set to turn on Channel1. Second press on Push button is set to turn off Channel1. The LED is blinking again.
Now this Push button is paired with Channel 1. In case there is another Push button/ batteryless switch needs to be paired, re-do the step 2).
- 3) Press L button on dimmer. The pairing is now moving to Channel 2. Any LED connected to Channel 2 is now blinking.
- 4) Press L button on dimmer. The pairing is now moving to Channel 3. Any LED connected to Channel 3 is now blinking.
- 5) Press L button on dimmer. The pairing is now moving to Channel 4. Any LED connected to Channel 4 is now blinking.
- 6) Press L button on dimmer. The pairing is now moving to Channel 5. Any LED connected to Channel 5 is now blinking.
- 7) Press L button on dimmer. The pairing is now moving to Channel 6. Any LED connected to Channel 6 is now blinking.
- 8) Press L button on dimmer to finish the pairing.
- 9) Now the system is set and ready to control the LED lamp on channel 1.

Dimming function:

Press the Push button to turn on the LED.
Press again and hold it till the light is dimmed to the level as request.
Release the Push button.

