



■ Features :

- Universal AC input / Full range
- Built in active PFC function, PF>0.95
- Protections: Short circuit / Overload / Over voltage / Over temperature
- Forced air cooling by built-in DC fan
- High power density 5.18w/in³
- Low profile:43mm thickness
- Built-in remote ON-OFF control
- Built-in remote sense function
- Active AC surge current limiting
- 3 years warranty



SPECIFICATION

MODEL	SP-480-3.3	SP-480-5	SP-480-12	SP-480-15	SP-480-24	SP-480-48	
OUTPUT	DC VOLTAGE	3.3V	5V	12V	15V	24V	48V
	RATED CURRENT	85A	85A	40A	32A	20A	10A
	CURRENT RANGE	0 ~ 85A	0 ~ 85A	0 ~ 43A	0 ~ 35A	0 ~ 22A	0 ~ 11A
	RATED POWER	280.5W	425W	480W	480W	480W	480W
	PEAK LOAD(10min.) Note.5	280.5W	425W	516W	525W	528W	528W
	RIPPLE & NOISE (max.) Note.2	80mVp-p	80mVp-p	120mVp-p	150mVp-p	150mVp-p	240mVp-p
	VOLTAGE ADJ. RANGE	2.9 ~ 3.6V	4.5 ~ 5.5V	10.8 ~ 13.2V	13.5 ~ 18V	22 ~ 27.6V	41 ~ 56V
	VOLTAGE TOLERANCE Note.3	±2.0%	±2.0%	±1.5%	±1.5%	±1.0%	±1.0%
	LINE REGULATION	±0.5%	±0.5%	±0.3%	±0.3%	±0.2%	±0.2%
	LOAD REGULATION	±1.0%	±1.0%	±0.5%	±0.5%	±0.5%	±0.5%
	SETUP, RISE TIME	1000ms, 80ms/230VAC 2500ms, 80ms/115VAC at full load					
HOLD UP TIME (Typ.)	18ms/230VAC 18ms/115VAC at full load						
INPUT	VOLTAGE RANGE Note.7	85 ~ 264VAC 120 ~ 370VDC					
	FREQUENCY RANGE	47 ~ 63Hz					
	POWER FACTOR (Typ.)	PF>0.95/230VAC PF>0.98/115VAC at full load					
	EFFICIENCY (Typ.)	73%	79%	85%	85%	87%	89%
	AC CURRENT (Typ.)	6.5A/115VAC	3.5A/230VAC				
	INRUSH CURRENT (Typ.)	20A/115VAC	40A/230VAC				
LEAKAGE CURRENT	<2mA / 240VAC						
PROTECTION	OVERLOAD	87 ~ 103A	87 ~ 103A	45.15 ~ 58.05A	36.75 ~ 47.25A	23.1 ~ 29.7A	11.55 ~ 14.85A
	OVER VOLTAGE	3.8 ~ 4.45V	5.75 ~ 6.75V	13.8 ~ 16.2V	18 ~ 21V	28.8 ~ 33.6V	57.6 ~ 67.2V
	OVER TEMPERATURE Note.4	80°C (TSW1) detect on heatsink of power transistor 90°C (TSW2) detect on heatsink of power diode Protection type : Shut down o/p voltage, recovers automatically after temperature goes down					
FUNCTION	REMOTE CONTROL RC+/RC-: 0 ~ 0.8V=power on ; 4 ~ 10V=power off						
ENVIRONMENT	WORKING TEMP.	-20 ~ +60°C (Refer to "Derating Curve")					
	WORKING HUMIDITY	20 ~ 90% RH non-condensing					
	STORAGE TEMP., HUMIDITY	-40 ~ +85°C, 10 ~ 95% RH					
	TEMP. COEFFICIENT	±0.03%/°C (0 ~ 50°C)					
SAFETY & EMC (Note 6)	VIBRATION	10 ~ 500Hz, 2G 10min./1cycle, 60min. each along X, Y, Z axes					
	SAFETY STANDARDS	UL60950-1, TUV EN60950-1 approved					
	WITHSTAND VOLTAGE	I/P-O/P:3KVAC I/P-FG:1.5KVAC O/P-FG:Short					
	ISOLATION RESISTANCE	I/P-O/P, I/P-FG:100M Ohms / 500VDC / 25°C / 70% RH					
	EMC EMISSION	Compliance to EN55022 (CISPR22) Class B, EN61000-3-2,-3					
OTHERS	EMC IMMUNITY	Compliance to EN61000-4-2,3,4,5,6,8,11, EN61000-6-2 (EN50082-2), light industry level, criteria A					
	MTBF	120.5K hrs min. MIL-HDBK-217F (25°C)					
	DIMENSION	278*127*43mm (L*W*H)					
NOTE	PACKING	1.7Kg; 6pcs/11.3Kg/0.67CUFT					
		<ol style="list-style-type: none"> All parameters NOT specially mentioned are measured at 230VAC input, rated load and 25°C of ambient temperature. Ripple & noise are measured at 20MHz of bandwidth by using a 12" twisted pair-wire terminated with a 0.1uf & 47uf parallel capacitor. Tolerance : includes set up tolerance, line regulation and load regulation. TSW1: Detect on heatsink of power transistor. TSW2: Detect on heatsink of output diode. 33% Duty cycle maximum within every 30 minute. Average output power should not exceed the rated power. The power supply is considered a component which will be installed into a final equipment. The final equipment must be re-confirmed that it still meets EMC directives. For guidance on how to perform these EMC tests, please refer to "EMI testing of component power supplies." (as available on http://www.meanwell.com) Derating may be needed under low input voltages. Please check the derating curve for more details. 					

Mechanical Specification

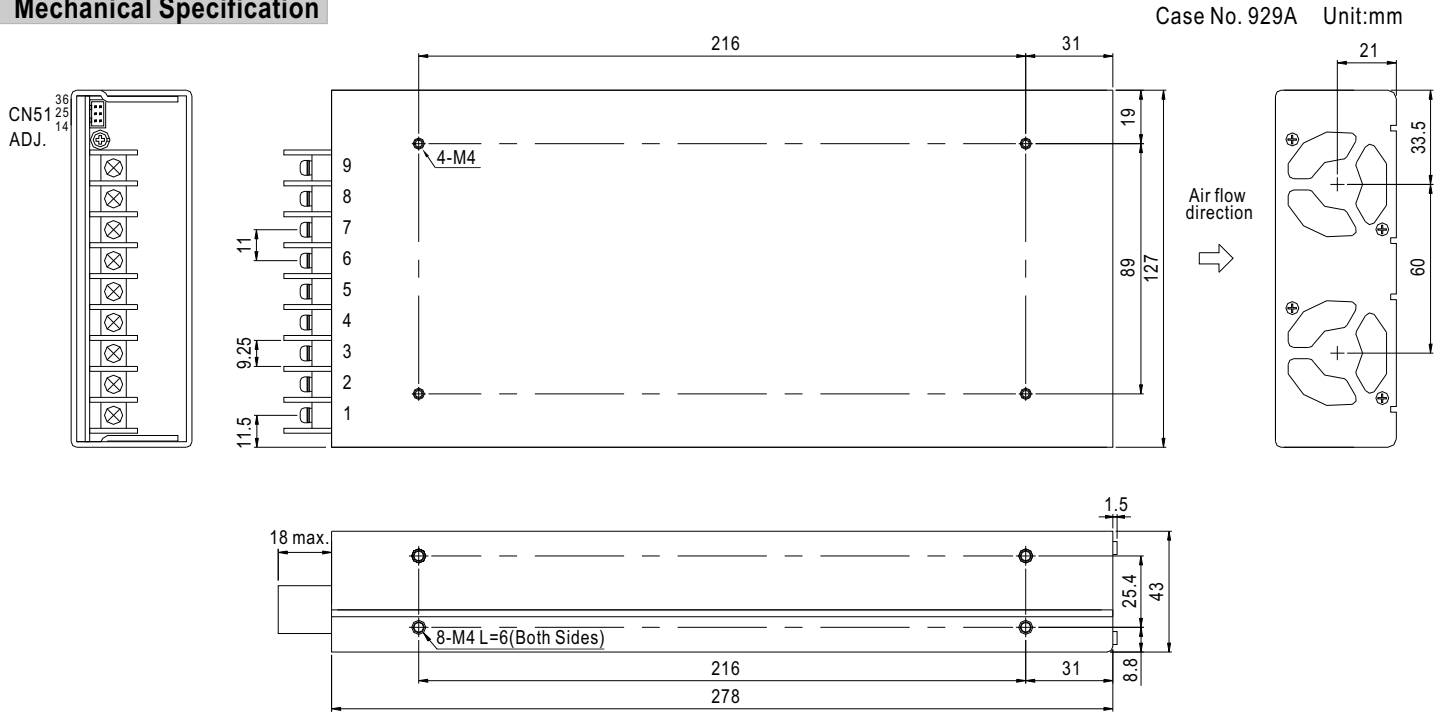

Terminal Pin No. Assignment :

Pin No.	Assignment	Pin No.	Assignment
1	AC/L	4~6	-V
2	AC/N	7~9	+V
3	FG \perp		

Connector Pin No. Assignment (CN51) : HRS DF11-6DP-2DS or equivalent

Pin No.	Assignment	Pin No.	Assignment	Mating Housing	Terminal
1	GND	4	N.C.	HRS DF11-6DS or equivalent	HRS DF11-**SC or equivalent
2	RC-	5	RC+		
3	-S	6	+S		

Block Diagram

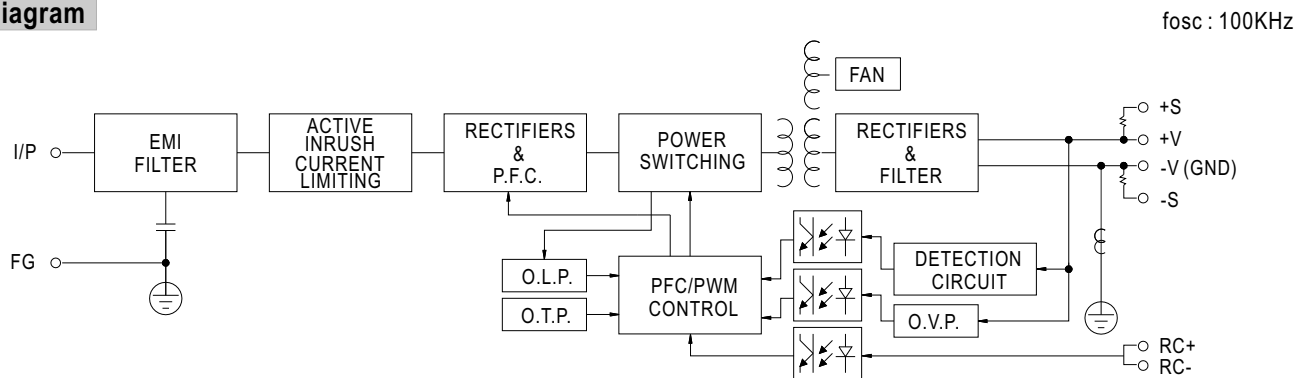

Derating Curve

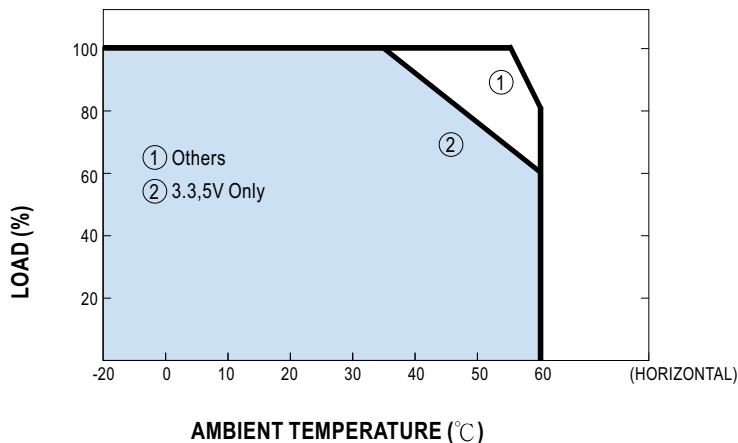

Static Characteristics

