

**Features :**

- Universal AC input / Full range
- AC input active surge current limiting
- High efficiency up to 92%
- Built-in 12V/0.1A auxiliary power
- Built-in active PFC function, PF>0.97
- Protections: Short circuit / Overload / Over voltage / Over temperature / Fan alarm
- Output voltage can be trimmed between 40 ~ 110% by 2 ~ 5.5VDC external control signal
- Output current can be trimmed between 40 ~ 110% by 2 ~ 5.5VDC external control signal
- Forced air cooling by built-in DC with fan speed control function
- High power density 9.44w/inch<sup>3</sup>
- 1U low profile 41mm
- DC OK Signal
- Built-in remote ON-OFF control
- Built-in remote sense function
- 3 years warranty

**SPECIFICATION**

MODEL		RSP-750-5	RSP-750-12	RSP-750-15	RSP-750-24	RSP-750-27	RSP-750-48
OUTPUT	DC VOLTAGE	5V	12V	15V	24V	27V	48V
	RATED CURRENT	100A	62.5A	50A	31.3A	27.8A	15.7A
	CURRENT RANGE	0 ~ 100A	0 ~ 62.5A	0 ~ 50A	0 ~ 31.3A	0 ~ 27.8A	0 ~ 15.7A
	RATED POWER	500W	750W	750W	751.2W	750.6W	753.6W
	RIPPLE & NOISE (max.) Note.2	150mVp-p	150mVp-p	150mVp-p	150mVp-p	150mVp-p	150mVp-p
	VOLTAGE ADJ. RANGE	4.75 ~ 5.5V	10 ~ 13.5V	13.5 ~ 16.5V	20 ~ 26.4V	24 ~ 30V	43 ~ 55V
	VOLTAGE TOLERANCE Note.3	±2.0%	±1.0%	±1.0%	±1.0%	±1.0%	±1.0%
	LINE REGULATION	±0.5%	±0.5%	±0.5%	±0.5%	±0.5%	±0.5%
	LOAD REGULATION	±2.0%	±0.5%	±0.5%	±0.5%	±0.5%	±0.5%
	SETUP, RISE TIME	1000ms, 50ms at full load					
HOLD UP TIME (Typ.)	16ms/230VAC 16ms/115VAC at full load						
INPUT	VOLTAGE RANGE Note.5	90 ~ 264VAC	127 ~ 370VDC				
	FREQUENCY RANGE	47 ~ 63Hz					
	POWER FACTOR (Typ.)	0.97/230VAC	0.98/115VAC at full load				
	EFFICIENCY (Typ.)	82%	87%	89%	90.5%	90.5%	92%
	AC CURRENT (Typ.)	5V : 5.6A/115VAC	2.8A/230VAC	12V~48V : 8.2A/115VAC		3.9A/230VAC	
	INRUSH CURRENT (Typ.)	25A/115VAC 40A/230VAC					
LEAKAGE CURRENT	<2.0mA / 240VAC						
PROTECTION	OVERLOAD	105 ~ 125% rated output power Protection type : Constant current limiting, recovers automatically after fault condition is removed					
	OVER VOLTAGE	5.75 ~ 6.75V	13.8 ~ 16.8V	17 ~ 20.5V	27.6 ~ 32.4V	31 ~ 36.5V	56.6 ~ 66.2V
	OVER TEMPERATURE	Shut down o/p voltage, recovers automatically after temperature goes down					
FUNCTION	AUXILIARY POWER(AUX)	12V @ 0.1A ; tolerance : ±10%					
	REMOTE ON/OFF CONTROL Note.6	Power on : short between on/off(pin13) & 12V-AUX(pin14) on CN50 Power off : open between on/off(pin13) & 12-AUX(pin14) on CN50					
	DC OK SIGNAL	The TTL signal out, PSU turn on = 0 ~ 1V ; PSU turn off = 3.3 ~ 5.6V					
	OUTPUT VOLTAGE TRIM Note.6	Adjustment of output voltage is possible between 40 ~ 110% by 2 ~ 5.5VDC external control signal					
	OUTPUT CURRENT TRIM	Adjustment of output current is between 40 ~ 110% by 2 ~ 5.5VDC external control signal					
ENVIRONMENT	WORKING TEMP.	-30 ~ +70°C (Refer to "Derating Curve")					
	WORKING HUMIDITY	20 ~ 90% RH non-condensing					
	STORAGE TEMP., HUMIDITY	-40 ~ +85°C, 10 ~ 95% RH					
	TEMP. COEFFICIENT	±0.03%/°C (0 ~ 50°C)					
	VIBRATION	10 ~ 500Hz, 2G 10min./1cycle, 60min. each along X, Y, Z axes					
SAFETY & EMC (Note 4)	SAFETY STANDARDS	UL60950-1, TUV EN60950-1 approved					
	WITHSTAND VOLTAGE	I/P-O/P:3KVAC I/P-FG:2KVAC O/P-FG:0.5KVAC					
	ISOLATION RESISTANCE	I/P-O/P, I/P-FG, O/P-FG:100M Ohms / 500VDC / 25°C / 70% RH					
	EMC EMISSION	Compliance to EN55022 (CISPR22), EN61000-3-2,-3					
	EMC IMMUNITY	Compliance to EN61000-4-2,3,4,5,6,8,11, EN55024, EN61000-6-2, EN61204-3, heavy industry level, criteria A					
OTHERS	MTBF	120.8K hrs min. MIL-HDBK-217F (25°C)					
	DIMENSION	250*127*41mm (L*W*H)					
	PACKING	1.64Kg; 6pcs/10.8Kg/1.1CUFT					
NOTE	1. All parameters NOT specially mentioned are measured at 230VAC input, rated load and 25°C of ambient temperature. 2. Ripple & noise are measured at 20MHz of bandwidth by using a 12" twisted pair-wire terminated with a 0.1uf & 47uf parallel capacitor. 3. Tolerance : includes set up tolerance, line regulation and load regulation. 4. The power supply is considered a component which will be installed into a final equipment. The final equipment must be re-confirmed that it still meets EMC directives. For guidance on how to perform these EMC tests, please refer to "EMI testing of component power supplies." (as available on <a href="http://www.meanwell.com">http://www.meanwell.com</a> ) 5. Derating may be needed under low input voltages. Please check the derating curve for more details. 6. The power supply unit will have no output if the shorting connector is not assembled. It contains three shorting wires: one is from on/off(pin13) to 12V-AUX(pin14), two is from PC(pin7) to PO(pin8) and the other is from PV(pin5) to PS(pin6). Please refer to function manual for details.						

■ Mechanical Specification

Case No.212A Unit:mm

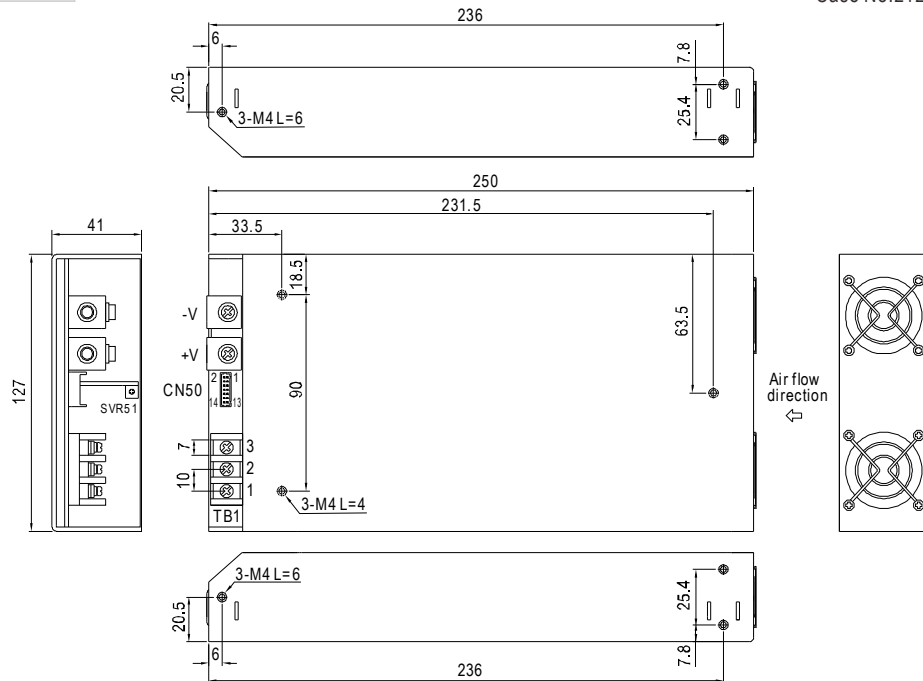

AC Input Terminal  
Pin No. Assignment

Pin No.	Assignment
1	AC/N
2	AC/L
3	FG $\perp$

Control Pin No. Assignment (CN50) : HRS DF11-14DP-2DS or equivalent

Pin No.	Assignment	Pin No.	Assignment	Pin No.	Assignment	Mating Housing	Terminal
1	+S	6	PS	12	G-AUX	HRS DF11-14DS or equivalent	HRS DF11-**-SC or equivalent
2	+VS	7	PC	13	ON/OFF		
3	-S	8	PO	14	12V-AUX		
4	-VS	9	DC-OK				
5	PV	10,11	GND				

■ Block Diagram

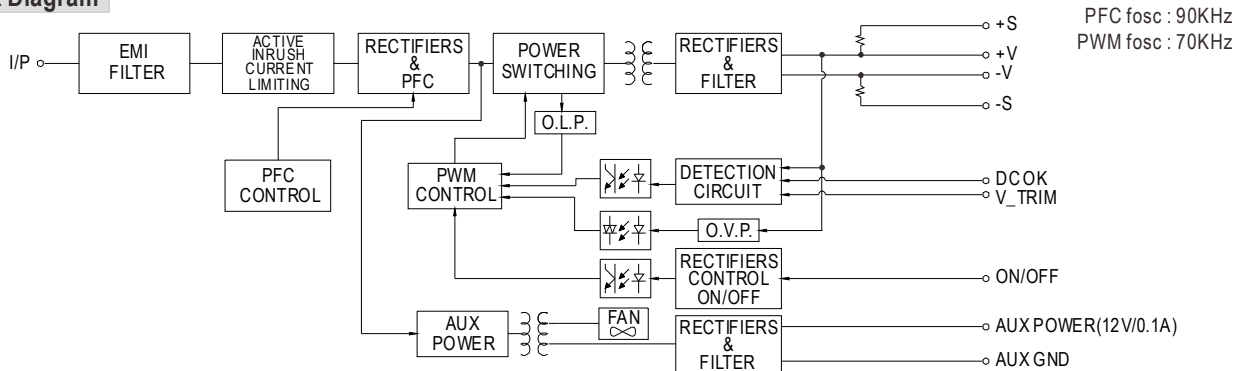

■ Derating Curve

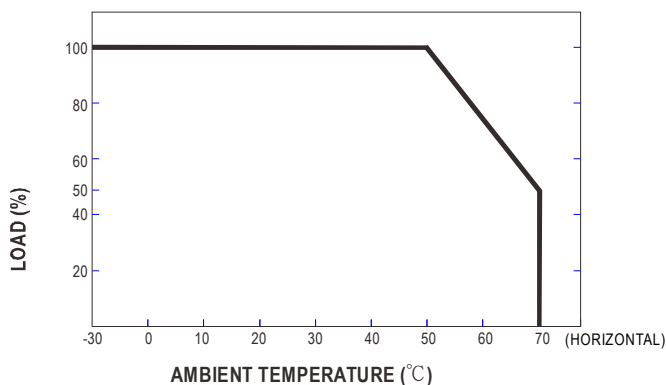

■ Static Characteristics

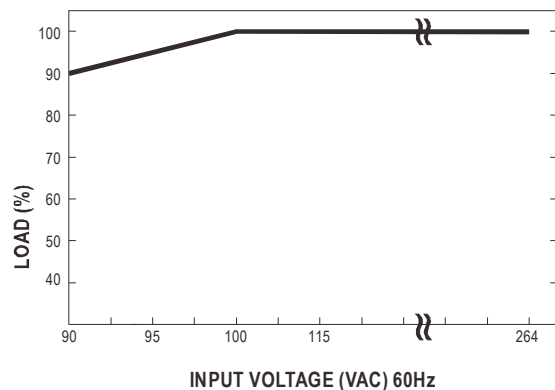

### ■ Function Description of CN50

Pin No.	Function	Description
1	+S	Positive sensing. The +S signal should be connected to the positive terminal of the load. The +S and -S leads should be twisted in pair to minimize noise pick-up effect. The maximum line drop compensation is 0.5V.
2	+VS	+V Signal. The +VS should be connected to the +S to reduce the noise when "output voltage TRIM" function is in use.
3	-S	Negative sensing. The -S signal should be connected to the negative terminal of the load. The -S and +S leads should be twisted in pair to minimize noise pick-up effect. The maximum line drop compensation is 0.5V.
4	-VS	-V Signal. The -VS should be connected to the -S to reduce the noise when "output voltage TRIM" function is in use.
5	PV	Connect to external DC voltage source for output voltage trimming, referenced to pin 10,11 (GND). Output voltage can be trimmed between 40 ~ 110% of the rated output voltage.
6	PS	Short connecting between PV (pin5) and PS (pin6) if "output voltage TRIM" function is not used.
7	PC	Connect to external DC voltage source for output current trimming, referenced output current can be trimmed between 40 ~ 110% of the rated output current. Please refer to function manual for details.
8	PO	Short connecting between PC (pin7) and PO (pin8) if output current trim function is not used.
9	DC_OK	Open collector signal, referenced to pin10,11(GND). Low when PSU turns on. The maximum sink current is 10mA and the maximum external voltage is 5.6V.
10,11	GND	These pins connect to the negative terminal (-V). Return for DC_OK Signal output.
12	G-AUX	Auxiliary voltage output ground. The signal return is isolated from the output terminals (+V & -V).
13	ON/OFF	Turns the output on and off by electrical or dry contact between pin 13 ( ON/OFF) and pin 14 (12V-AUX). Short: Power ON, Open: Power OFF.
14	12V-AUX	Auxiliary voltage output, 10.8~13.2V, referenced to pin 12(G-AUX). The maximum load current is 0.1A. This output is not controlled by the "remote ON/OFF control".

### ■ Function Manual

#### 1. "Remote ON/OFF" and "Output voltage trim" and "Output current trim" functions are not used.

- (1) The power supply unit will have no output if the shorting connector (accessory comes along with the PSU) is not assembled. It contains three shorting wires : one is from ON/OFF (pin13) to 12V-AUX (pin14), two is from PV(pin5) to PS (pin6) and the other is from PC (pin7) to PO (pin8).
- (2) Factory setting is shorted as Fig1.1

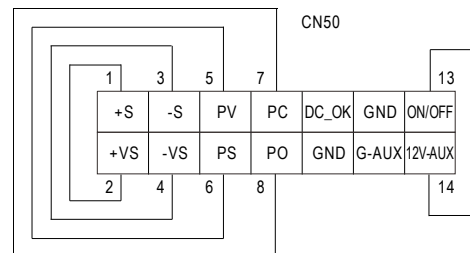
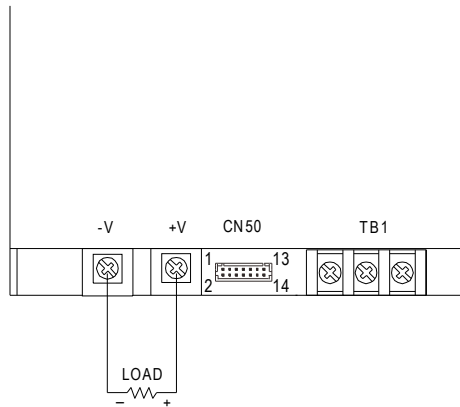
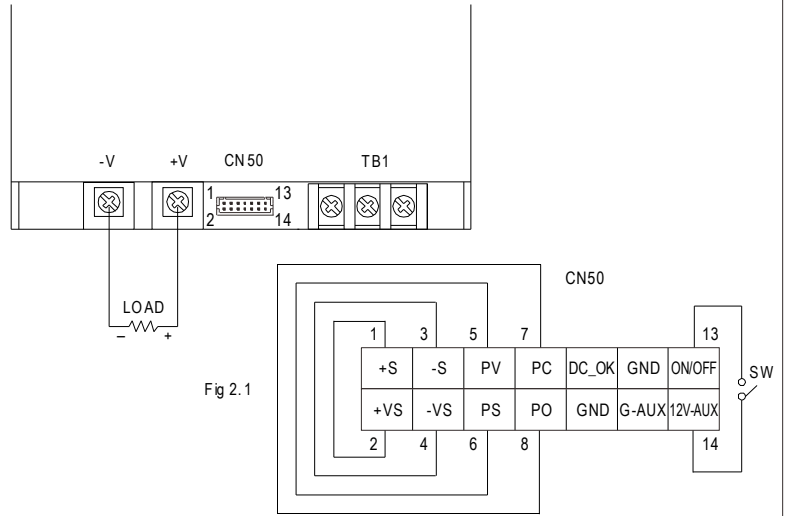

Fig 1.1 (Shorting connector)

**2.Remote ON/OFF**

The PSU can be turned ON/OFF by using the "Remote ON/OFF" function

Between ON/OFF(pin13) and 12V-AUX(pin14)	Output Status
SW close (Short)	PSU ON
SW open (Open)	PSU OFF



**3.DC\_OK signal**

"DC\_OK" is an open collector signal. It indicates the output status of the PSU. It can operate in two ways : One is sinking current from external TTL signal ; the other is sending out a TTL voltage signal.

**3-1 Sink current :**

The maximum sink current is 10mA and the maximum external voltage is 5.6V.

**3-2 TTL voltage signal :**

Between DC- OK(pin9) and GND(pin10&11)	Output Status
0 ~ 1V	PSU ON
3.3 ~ 5.6V	PSU OFF

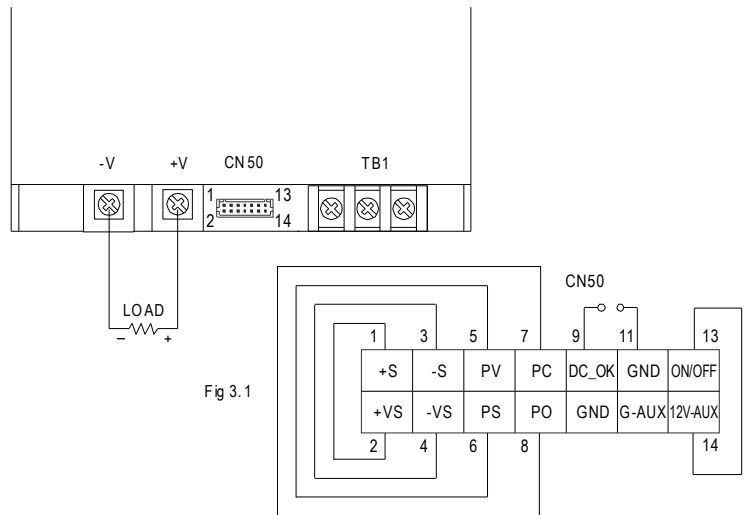

**4.Remote Sense**

The remote sensing compensates voltage drop on the load wiring up to 0.5V.

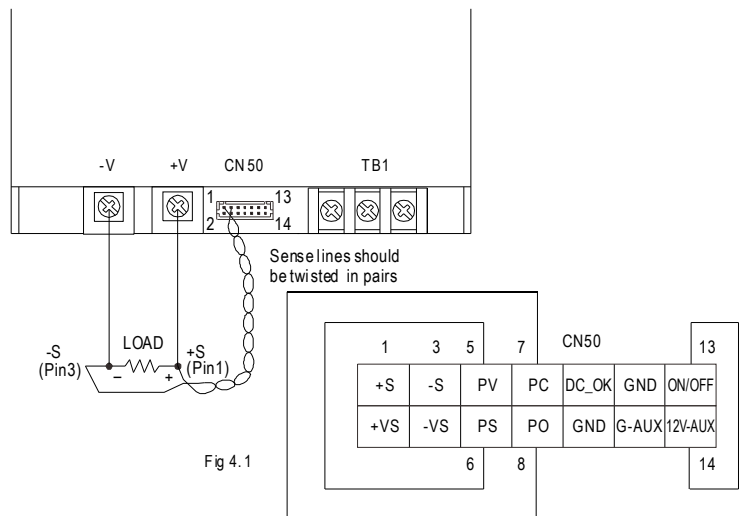



## 750W Single Output Power Supply

# RSP-750 series

### 5. Output Voltage TRIM

Output voltage of RSP-750 can be trimmed between 40% ~ 110% of its rated value by the following methods :

(1) Using an external DC source (2~5.5VDC) between "PV"(pin5) and "GND"(pin10, 11) that is shown in Fig5.1

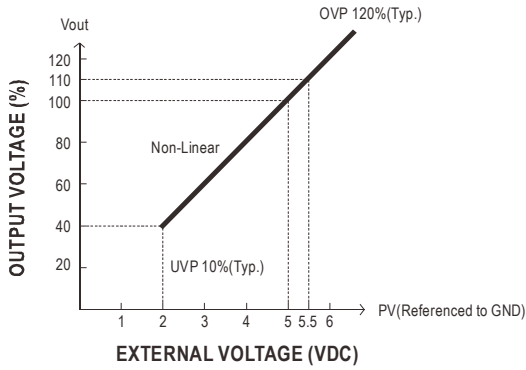

Note: External voltage < 0.5V Vo may be the UVP need to restart.

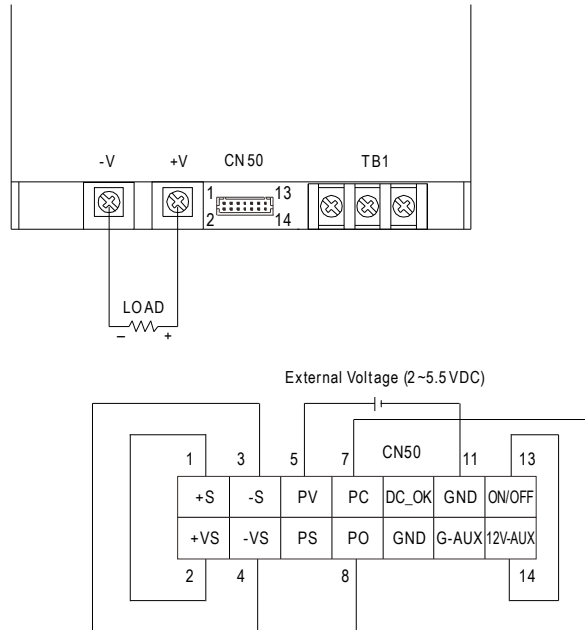

Fig 5.1

### 6. Output Current TRIM

Output current of RSP-750 can be trimmed between 40% ~ 110% of its rated value by the following methods :

(1) Using external voltage source between "PC"(pin7) and "GND"(pin10, 11) that is shown in Fig6.1

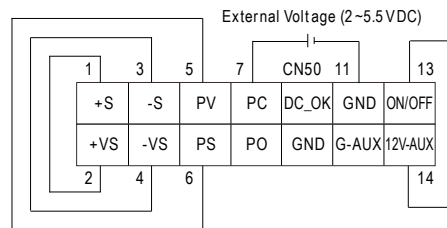
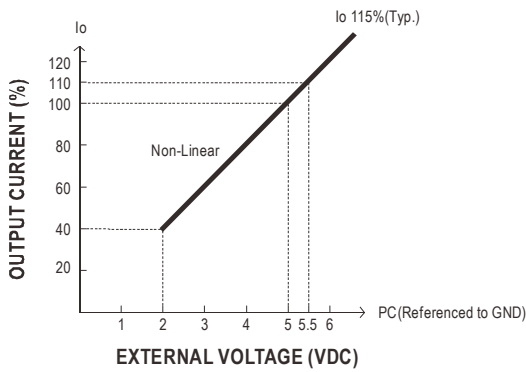

Fig 6.1