



## 600W with PFC and Parallel Function

# PSP-600 series



### ■ Features :

- Universal AC input / Full range
- Built-in active PFC function
- Protections: Short circuit / Overload / Over voltage / Over temperature
- Forced air cooling by built-in DC fan
- With DC OK Signal output
- Current sharing up to 2400W(3+1)
- Built-in remote ON-OFF control
- Built-in remote sense function
- Fixed switching frequency at PFC:88KHz PWM:100KHz
- 3 years warranty



### SPECIFICATION

MODEL	PSP-600-5	PSP-600-12	PSP-600-13.5	PSP-600-15	PSP-600-24	PSP-600-27	PSP-600-48	
OUTPUT	DC VOLTAGE	5V	12V	13.5V	15V	24V	27V	48V
	RATED CURRENT	80A	50A	44.5A	40A	25A	22.2A	12.5A
	CURRENT RANGE	0 ~ 80A	0 ~ 50A	0 ~ 44.5A	0 ~ 40A	0 ~ 25A	0 ~ 22.2A	0 ~ 12.5A
	RATED POWER	400W	600W	600.75W	600W	600W	599.4W	600W
	RIPPLE & NOISE (max.) Note.2	180mVp-p	240mVp-p	240mVp-p	240mVp-p	240mVp-p	240mVp-p	300mVp-p
	VOLTAGE ADJ. RANGE	4.75 ~ 5.5V	10 ~ 13.2V	12 ~ 15V	13.5 ~ 18V	20 ~ 26.4V	24 ~ 30V	41 ~ 56V
	VOLTAGE TOLERANCE Note.3	±2.0%	±1.0%	±1.0%	±1.0%	±1.0%	±1.0%	±1.0%
	LINE REGULATION	±0.5%	±0.5%	±0.5%	±0.5%	±0.5%	±0.5%	±0.5%
	LOAD REGULATION	±1.0%	±0.5%	±0.5%	±0.5%	±0.5%	±0.5%	±0.5%
	SETUP, RISE TIME	1500ms, 50ms at full load						
HOLD UP TIME (Typ.)	20ms at full load							
INPUT	VOLTAGE RANGE Note.5	88 ~ 264VAC	124 ~ 370VDC					
	FREQUENCY RANGE	47 ~ 63Hz						
	POWER FACTOR (Typ.)	0.95/230VAC	0.99/115VAC at full load					
	EFFICIENCY(Typ.)	79%	84%	85%	85%	86%	86%	87%
	AC CURRENT (Typ.)	6.8A/115VAC	3.4A/230VAC					
	INRUSH CURRENT (Typ.)	20A/115VAC	40A/230VAC					
LEAKAGE CURRENT	<1.3mA/240VAC							
PROTECTION	OVERLOAD	105 ~ 135% rated output power Protection type : Constant current limiting, recovers automatically after fault condition is removed						
	OVER VOLTAGE	5.75 ~ 6.75V	13.8 ~ 16.2V	15.5 ~ 18.2V	18 ~ 21V	27.6 ~ 32.4V	31 ~ 36.5V	57.6 ~ 67.2V
	OVER TEMPERATURE	+5V: 95°C (TSW1) detect on heatsink of power transistor; 95°C (TSW51) detect on heatsink of power diode +12V ~ +48V: 85°C (TSW1) detect on heatsink of power transistor; 80°C (TSW51) detect on heatsink of power diode Protection type : Shut down o/p voltage, re-power on to recover						
FUNCTION	REMOTE CONTROL	RC+/RC-: Short = power on ; Open = power off						
	POK SIGNAL	PSU turn on: 3.3V ~ 5.6V		PSU turn off: 0V ~ 1V				
ENVIRONMENT	WORKING TEMP.	-20 ~ +60°C (Refer to "Derating Curve")						
	WORKING HUMIDITY	20 ~ 90% RH non-condensing						
	STORAGE TEMP., HUMIDITY	-40 ~ +85°C, 10 ~ 95% RH						
	TEMP. COEFFICIENT	±0.03%/°C (0 ~ 50°C)						
	VIBRATION	10 ~ 500Hz, 2G 10min./1cycle, period for 60min. each along X, Y, Z axes						
SAFETY & EMC (Note 4)	SAFETY STANDARDS	UL60950-1, TUV EN60950-1 approved						
	WITHSTAND VOLTAGE	I/P-O/P:3KVAC	I/P-FG:2KVAC	O/P-FG:0.5KVAC				
	ISOLATION RESISTANCE	I/P-O/P, I/P-FG, O/P-FG:100M Ohms / 500VDC / 25°C / 70% RH						
	EMC EMISSION	Compliance to EN55022 (CISPR22) Class B, EN61000-3-2,-3						
OTHERS	EMC IMMUNITY	Compliance to EN61000-4-2,3,4,5,6,8,11, light industry level, criteria A						
	MTBF	116.4K hrs min. MIL-HDBK-217F (25°C)						
	DIMENSION	170*120*93mm (L*W*H)						
NOTE	PACKING	1.9Kg; 8pcs/15.5Kg/1.06CUFT						
		1. All parameters NOT specially mentioned are measured at 230VAC input, rated load and 25°C of ambient temperature. 2. Ripple & noise are measured at 20MHz of bandwidth by using a 12" twisted pair-wire terminated with a 0.1uf & 47uf parallel capacitor. 3. Tolerance : includes set up tolerance, line regulation and load regulation. 4. The power supply is considered a component which will be installed into a final equipment. The final equipment must be re-confirmed that it still meets EMC directives. For guidance on how to perform these EMC tests, please refer to "EMI testing of component power supplies." (as available on <a href="http://www.meanwell.com">http://www.meanwell.com</a> ) 5. Derating may be needed under low input voltages. Please check the derating curve for more details.						

Case No.910A Unit:mm

## Mechanical Specification

RS Connector(CN5) : JST B-XH or equivalent

Pin No.	Assignment	Mating Housing	Terminal
1	RS+	JST XHP or equivalent	JST SXH-001T or equivalent
2	RS-		

Terminal Pin No. Assignment

Pin No.	Assignment
1	AC/L
2	AC/N
3	FG $\perp$
4	P(Current Share)
5	POK
6	R.C. G
7	R.C.
8~11	DC OUTPUT +V
12~15	DC OUTPUT -V

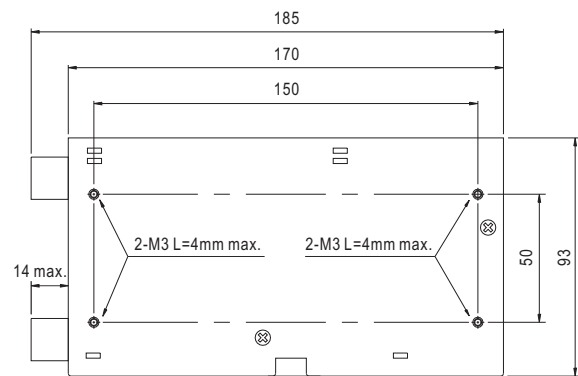
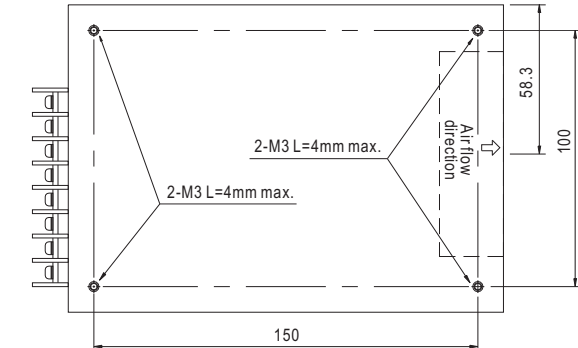
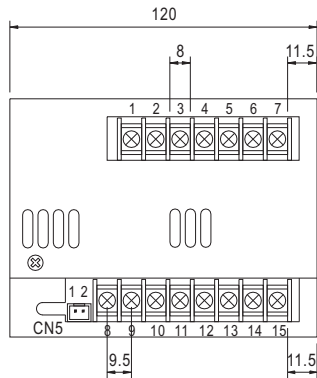

## Block Diagram

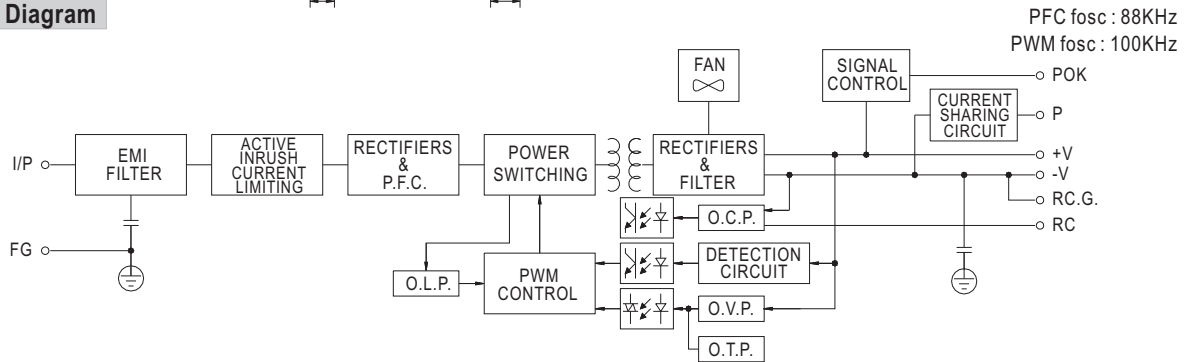

## Derating Curve

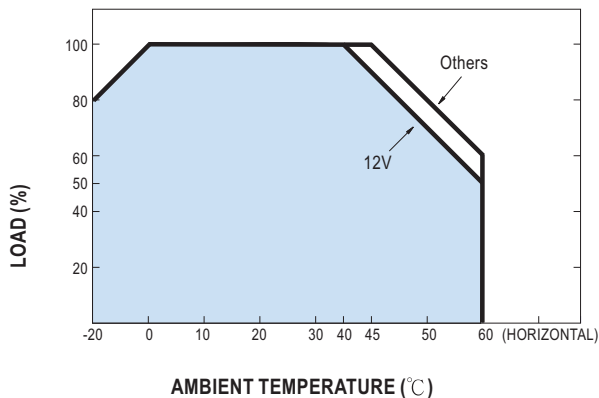

## Output Derating VS Input Voltage

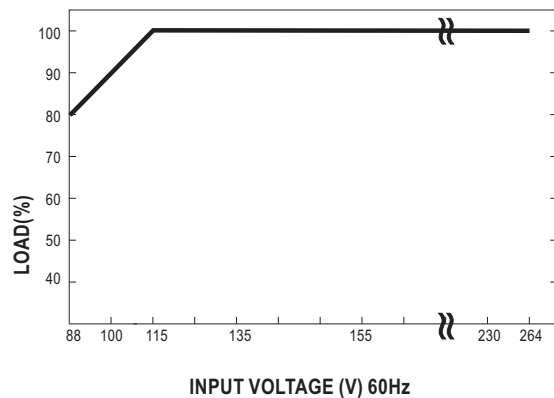



600W with PFC and Parallel Function

**PSP-600 series**

**Control Terminal Instruction Manual**

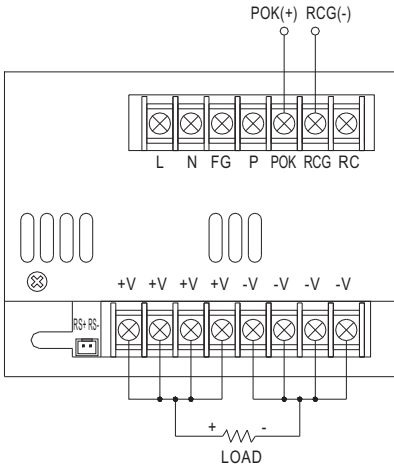

**POK Signal**

POK Signal is the voltage difference between "RCG" and "POK" pin output POK Signal for TTL level signal  
 PSU turn on: 3.3V ~ 5.6V  
 PSU turn off: 0V ~ 1V

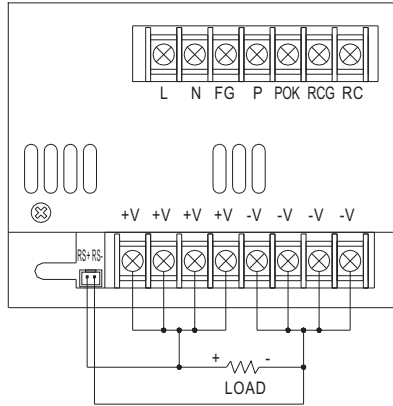

**Remote Sensing**

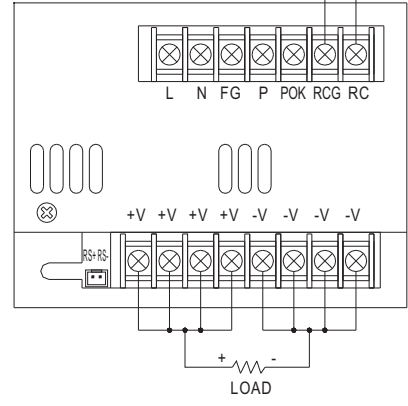

**Remote Control**

Power ON: RCG and RC for short  
 Power OFF: RCG and RC for open

**Parallel Operation with Remote Sensing**

- (1) Parallel operation is available by connecting the units shown as below (+S, -S and P are connected mutually in parallel) :
- (2) The voltage difference among each output should be minimized that less than 0.2V is required.
- (3) The total output current must not exceed the value determined by the following equation (Output current at parallel operation)  
 = (The rated current per unit) x (Number of unit) x 0.9.
- (4) In parallel operation 4 units is the maximum, please consult the manufacture for other applications.
- (5) When remote sensing is used in parallel operation, the sensing wire must be connected only to the master unit.
- (6) When in parallel operation, the minimum output load should be greater than 3% of total output load.  
 (Min. load > 3% rated current per unit x number of unit)

