



New

# EntelliGuard™ L

Power Circuit Breaker  
Effective Simplicity



GE imagination at work



- 2. Features and Benefits
- 6. Performance Ratings

## Air Circuit Breakers

Order Codes

Electronic Trip Units

Breaker Accessories

Application Guide

Dimensions

Numerical index

Intro

A

B

C

D

E

X



## New line of Air Circuit Breakers

- Evolved from a global platform
- Designed for simplicity
- Manufactured in the European Union



## Range and performance

- 400 to 4000A in 2 frame sizes
- Designed to and meets the IEC 60947
- 3P and 4P versions in fixed and withdrawable configurations
- Choice of 50kA or 65kA ratings
- Icu= Ics = Icw for the full range
- Suitable for up to 690V AC
- Designed to be selective

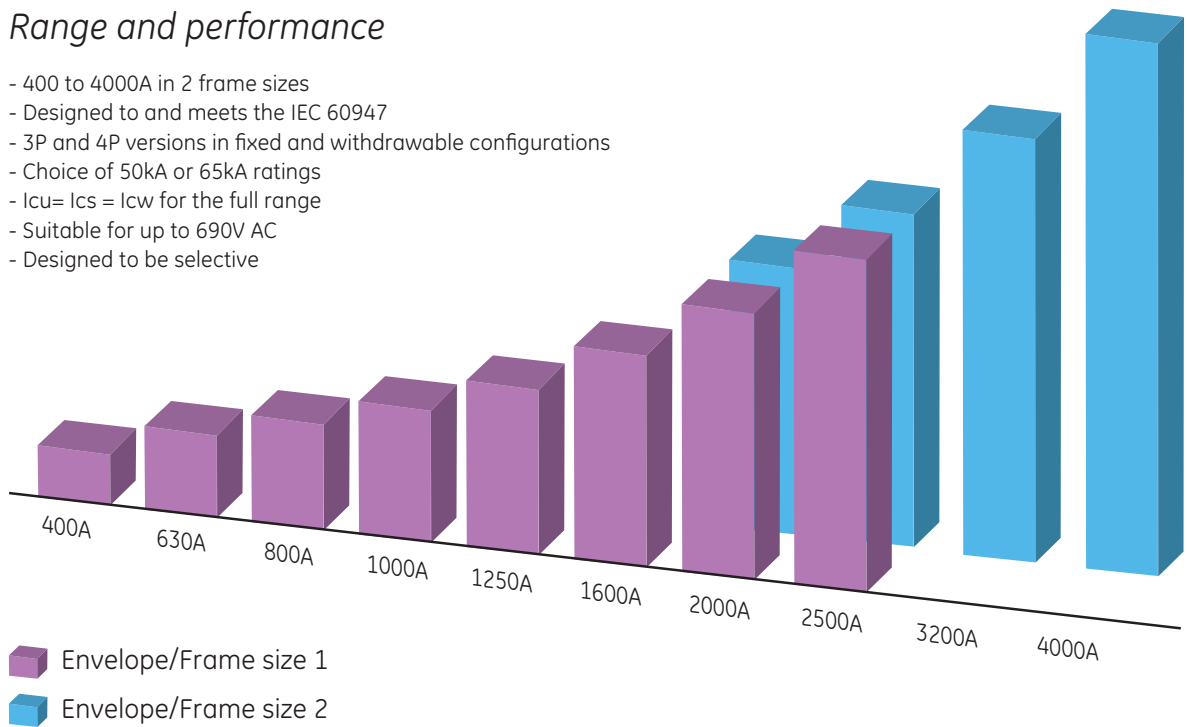

■ Envelope/Frame size 1  
■ Envelope/Frame size 2

## Installation

- Compact and modular build
- No derating up to an ambient of 50°C
- Front-mounted snap-fit accessories
- Accessories and Control voltage indication on the front fascia

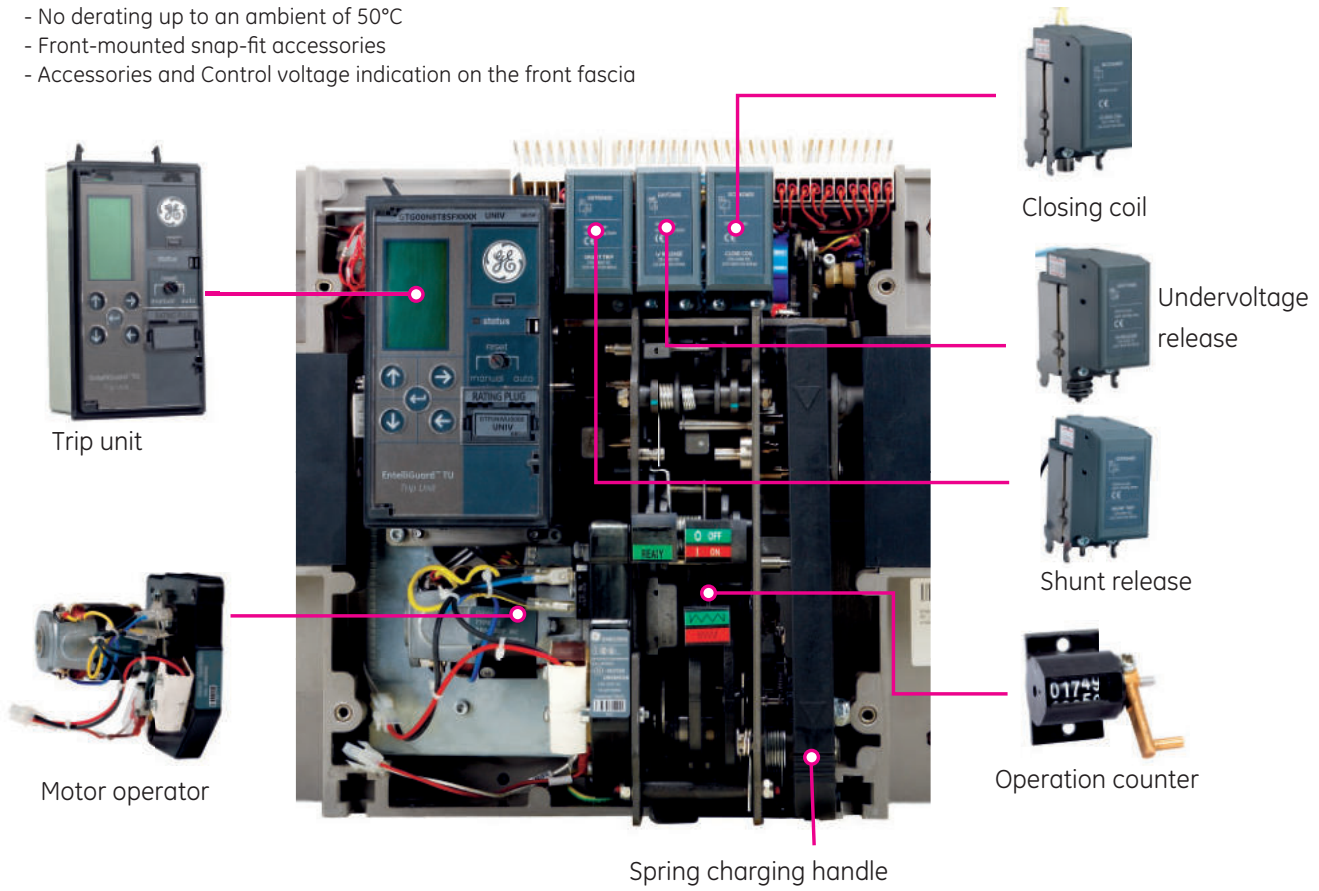

Trip unit

Motor operator

Closing coil

Undervoltage release

Shunt release

Operation counter

Spring charging handle

## Protection

- State-of-the-art micro-processor based trip unit
- TRUE-RMS sensing
- Standard large LCD display
- Touch-pad based programming navigation
- Micro-processor based trip units offering high accuracy
- Standard event logger and diagnostics



## Front fascia

- ① Installed accessory indicators
- ② Electronic trip unit
- ③ Manual charging handle
- ④ ON and OFF buttons
- ⑤ Contact position indicator ON/OFF
- ⑥ Ready to close indicator
- ⑦ Mechanical spring charge indication
- ⑧ Operation counter
- ⑨ Slot to fix breaker key interlock
- ⑩ Mechanical position indicator
- ⑪ Racking handle pad lock
- ⑫ Racking handle
- ⑬ Catalogue code

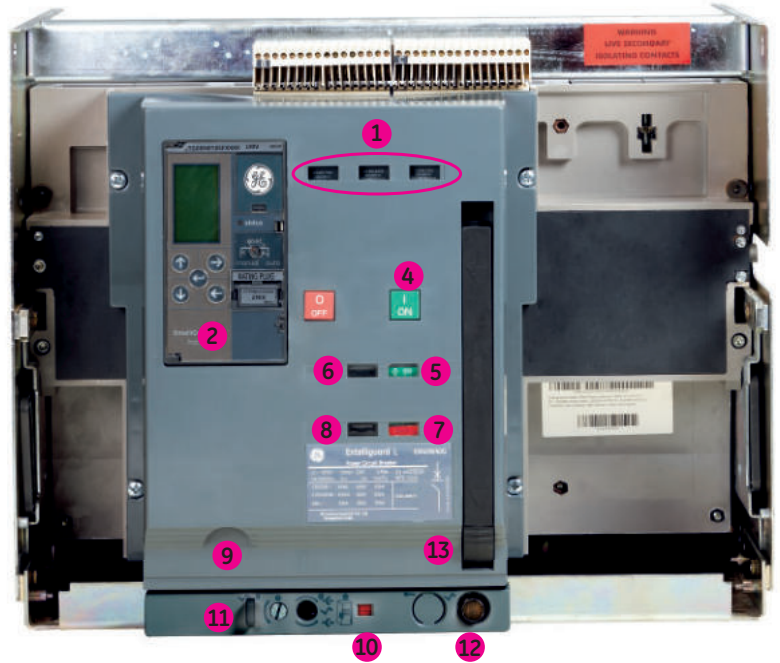

## GT- trip unit



### Advanced electronic trip unit

- ① 1 LCD screen with following menu options:
  - **Setup**  
Allows adjustment of values and settings of all parameters
  - **Meter**  
An ammeter is available on all 3 phases and neutral
  - **Status**  
Breaker in ON / OFF / Trip position
  - **Events**  
Trip history with the fault indication
- ② 4 setting and 1 enter key to access trip unit functionality
- ③ Manual or automatic reset facility

## EntelliGuard™

The EntelliGuard is a new line of Air Circuit Breakers developed as a global product meeting IEC standards.

The L version of this breaker is a line of three and four pole devices ranging from 400A to 4000A in two frame sizes with a fault interruption ratings of 50 and 65kA.

The design offer a unique combination of high fault current withstand ratings, short fault interruption times and selectivity.

The device includes a new state-of-the-art highly accurate trip unit that enables the circuit breaker to reliably protect itself and it's environment.

These Power Circuit Breakers are designed to allow multiple interruptions of fault currents and can be used in AC networks with voltages up to 690V.



### Selective and fast

EntelliGuard has been designed to offer an uncompromising combination of a high speed interruption at high fault levels. Values of 40 milliseconds or less can be achieved whilst maintaining selectivity.

The circuit breaker is designed to remain closed on a fault as per user settable time value when the fault level lies within the range of short time delay option, and for 15 milliseconds when the fault level attains instantaneous protection range value.

This instantaneous device includes programming that in normal circumstances waits until the downstream breaker trips.

### Uncompromising ... Reliability

EntelliGuard™ has been designed as a modern 'Power Circuit Breaker' without neglecting its GE's heritage of more than 50 years in building Air Circuit Breakers.

The result: a device with a proven electrical and mechanical life span independent of its operation mode. Be it manual, electrical or by means of the installed shunt and/or undervoltage releases.

### Hi-Performance: complete line

All power circuit breakers are designed to allow multiple interruptions of fault currents. Here the tested and certified service breaking capacity value is in all cases equal to the stated ultimate breaking capacity.

### Hi-Performance: current ratings in enclosures

EntelliGuard™ Air Circuit Breakers have been designed with low power dissipation values and allow relatively high currents at high ambient temperatures.

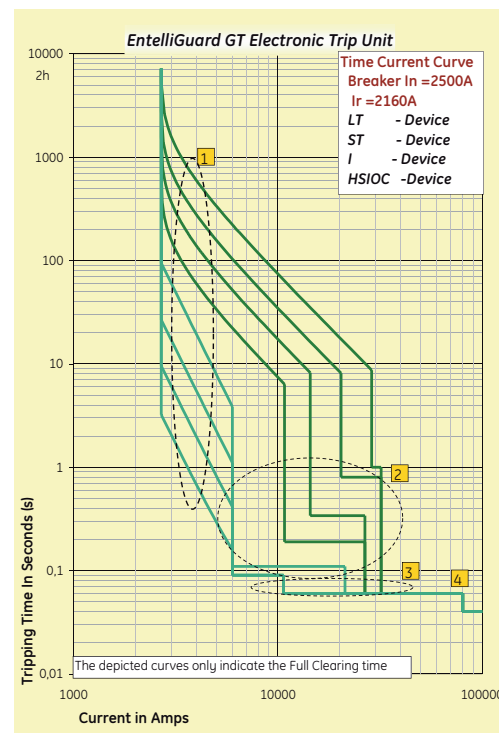

1. Overload protection (LT) with 22 bands
2. Timed short-circuit protection (STD) with 17 bands
3. Selective instantaneous protection (I)
4. Hi-Speed trip (HSIOC)

## EN 60947-2 standard

Power Circuit Breaker type		LG04		LG07		LG08		LG10		LG13	
		S	N	S	N	S	N	S	N	S	N
Air Circuit Breaker denomination											
Poles	Number of	3,4		3,4		3,4		3,4		3,4	
Rated insulation voltage	Ui (Volts)	1000		1000		1000		1000		1000	
Rated impulse withstand voltage	Uimp [Kilovolt]	12		12		12		12		12	
Rated operational voltage Ue	Volts AC	690		690		690		690		690	
Category of use		B		B		B		B		B	
Suitable for use as a isolator		YES		YES		YES		YES		YES	
Rated current In	A at 50 o C	400		630		800		1000		1250	
Ultimate breaking capacity Icu (kA)	230/240V- 440V AC	50	65	50	65	50	65	50	65	50	65
	500V AC	50	65	50	65	50	65	50	65	50	65
	690V AC	40	40	40	40	40	40	40	40	40	40
Service breaking capacity Ics (kA)	230/240V- 440V AC	50	65	50	65	50	65	50	65	50	65
	500V AC	50	65	50	65	50	65	50	65	50	65
	690V AC	40	40	40	40	40	40	40	40	40	40
Interruption time I < Icw	at 500V AC	60ms		60ms		60ms		60ms		60ms	
Interruption time I >= Icw	at 500V AC	30ms		30ms		30ms		30ms		30ms	
Closing time with closing call		60ms		60ms		60ms		60ms		60ms	
Opening time with closing shunt		40ms		40ms		40ms		40ms		40ms	
Short-circuit withstand Icw (kA)	1 second	50	65	50	65	50	65	50	65	50	65
	3 seconds	30	50	30	50	30	50	30	50	30	50
Short-circuit making current Icm 220-500V AC	kA Peak	105	143	105	143	105	143	105	143	105	143
Mechanical endurance	With maintenance	20000		20000		20000		20000		20000	
	Without maintenance	10000		10000		10000		10000		10000	
Electrical endurance (CO operations at 440V AC)	Without maintenance	5000		5000		5000		5000		5000	

## Electronic Trip Unit

GT-L type with Ammeter	LT, ST, I, GF	Possible	Possible	Possible	Possible	Possible
------------------------	---------------	----------	----------	----------	----------	----------

## EN 60947-3 standard

Power Circuit Breaker type		LJ04		LJ07		LJ08		LJ10		LJ13	
		Non Auto		Non Auto		Non Auto		Non Auto		Non Auto	
Isolator denomination		R		R		R		R		R	
Poles	Number of	3,4		3,4		3,4		3,4		3,4	
Rated insulation voltage	Ui (Volts)	1000		1000		1000		1000		1000	
Rated impulse withstand voltage	Uimp [Kilovolt]	12		12		12		12		12	
Suitable for use as a isolator		YES		YES		YES		YES		YES	
Rated operational voltage Ue	Volts AC	690		690		690		690		690	
Rated current In	A at 50 o C	400		630		800		1000		1250	
Short-circuit withstand Icw (kA)	1 second	42		42		42		42		42	
	3 seconds	30		30		30		30		30	
Short-circuit making current Icm 220-500V AC	kA Peak	88,2		88,2		88,2		88,2		88,2	
Mechanical endurance	With maintenance	20000		20000		20000		20000		20000	
	Without maintenance	10000		10000		10000		10000		10000	
Electrical endurance (CO operations at 440V AC)	Without maintenance	5000		5000		5000		5000		5000	

## Installation

Fixed pattern		LJ04		LJ07		LJ08		LJ10		LJ13	
Dimensions in mm	Height	438		438		438		438		438	
	Width 3pole	338		338		338		338		338	
	Width 4pole	438		438		438		438		438	
	Depth <sup>(1)</sup>	328		328		328		328		328	
Available connection modes	Rear Horizontal	X		X		X		X		X	
	Rear Vertical	X		X		X		X		X	
	Front	X		X		X		X		X	
Weights in kg	3 pole	42		42		42		42		42	
	4 pole	50		50		50		50		50	
Draw-out pattern		LJ04		LJ07		LJ08		LJ10		LJ13	
Dimensions in mm	Height	439		439		439		439		439	
	Width 3pole	331		331		331		331		331	
	Width 4pole	431		431		431		431		431	
	Depth <sup>(2)</sup>	432		432		432		432		432	
Available connection modes	Rear Horizontal	X		X		X		X		X	
	Rear Universal <sup>(2)</sup>	X		X		X		X		X	
	Front	X		X		X		X		X	
Weights in kg	3 pole	60		60		60		60		60	
	4 pole	72		72		72		72		72	

(1) With horizontal rear connections: Indicated depth value is the required panel dimension.  
 (2) T stubs can be rotated and used for both vertical & horizontal rear connection.  
 (3) The 4000A rating is only available with rear vertical connections.





LG16		LG20				LG25				LG32		LG40	
S	N	S	N	C	D	S	N	C	D	C	D	C	D
3,4		3,4				3,4				3,4		3,4	
1000		1000				1000				1000		1000	
12		12				12				12		12	
690		690				690				690		690	
B		B				B				B		B	
YES		YES				YES				YES		YES	
1600		2000				2500				3200		4000	
50	65	50	65	50	65	50	65	50	65	50	65	50	65
50	65	50	65	50	65	50	65	50	65	50	65	50	65
40	40	40	40	50	50	40	40	50	50	40	40	50	50
50	65	50	65	50	65	50	65	50	65	50	65	50	65
50	65	50	65	50	65	50	65	50	65	50	65	50	65
40	40	40	40	40	40	40	40	40	40	40	40	40	40
60ms		60ms		60ms		60ms		60ms		60ms		60ms	
30ms		30ms		30ms		30ms		30ms		30ms		30ms	
60ms		60ms		60ms		60ms		60ms		60ms		60ms	
40ms		40ms		40ms		40ms		40ms		40ms		40ms	
50	65	50	65	50	65	50	65	50	65	50	65	50	65
30	50	30	50	50	50	30	50	50	50	50	50	50	50
105	143	105	143	105	143	105	143	105	143	110	143	110	143
20000		20000				20000				20000		20000	
10000		10000				10000				10000		10000	
5000		5000				5000				5000		5000	

Possible	Possible	Possible	Possible	Possible
----------	----------	----------	----------	----------

LJ16		LJ20		LJ25		LJ32	LJ40
Non Auto		Non Auto		Non Auto		Non Auto	Non Auto
R		R	C	R	C	C	C
3,4		3,4	3,4	3,4	3,4	3,4	3,4
1000		1000	1000	1000	1000	1000	1000
12		12	12	12	12	12	12
YES		YES	YES	YES	YES	YES	YES
690		690	690	690	690	690	690
1600		2000		2500		3200	4000
42		42	50	42	50	50	50
30		30	50	30	50	50	50
88,2		88,2	105	88,2	105	105	105
20000		20000		20000		20000	20000
10000		10000		10000		10000	10000
5000		5000		5000		5000	5000

438	438	438	438	438	438	438	438
338	338	432	338	432	432	432	432
438	438	562	438	562	562	562	562
328	328	328	328	328	328	328	393 <sup>(3)</sup>
X	X	X	X	X	X	X	---
X	X	X	X	X	X	X	Rear Vertical <sup>(3)</sup>
X	X	X	X	X	X	X	X
42	52	63	58	63	63	63	69
50	65	76	73	76	76	76	84
439	439	439	439	439	439	439	439
331	331	421	421	421	421	421	421
431	431	551	551	551	551	551	551
432	432	432	432	432	432	432	534
X	X	X	X	X	X	X	---
X	X	X	X	X	X	X	X
X	X	X	X	X	X	X	Rear Vertical <sup>(3)</sup>
60	72	105	74	105	105	105	120
72	88	130	91	130	130	130	145

## Intro

A

B

C

D

E

X



## Notes

A large grid of dotted lines for taking notes, covering the majority of the page.



**Power Circuit Breakers**

- A.2 EntelliGuard L: How to order in eight steps
- A.4 Basic breakers executed in a fixed mounting pattern
- A.6 Isolators or Non Automatic breakers in a fixed mounting pattern
- A.5-A.7 Non standard connection options for fixed breakers & isolators
  - A.4 Basic breakers: Drawout breakers; Moving portion only
  - A.6 Isolators or Non Automatic breakers: Drawout breakers; Moving portion only
- A.5-A.7 Factory mounted cassettes for drawout breakers
  - A.8 Factory mounted Trip Units
- A.9-A.10 Factory mounted internal accessories.  
(Motor Operators Coils, Auxiliary Contacts Releases etc.)
  - A.11 Field mountable internal accessories  
(Motor Operators Coils, Auxiliary Contacts Releases etc.)
  - A.12 Cassettes for Drawout breakers
- A.13-A.14 Other accessories
  - A.14 Spare parts
- A.16-A.17 Alternative Ordering Method and 18-digit Catalogue Number for breakers
- A.18 Alternative Ordering Method and 12-digit Catalogue Number for cassettes
- A.19 Overview : Factory mounted available standard breakers,  
Cassettes & Trip Units
- A.20 Overview : Factory and/or Field mountable accessories & spares

Air Circuit Breakers

Order Codes

Electronic Trip Units

Breaker Accessories

Application Guide

Dimensions

Numerical index

Intro

A

B

C

D

E

X



# How to order

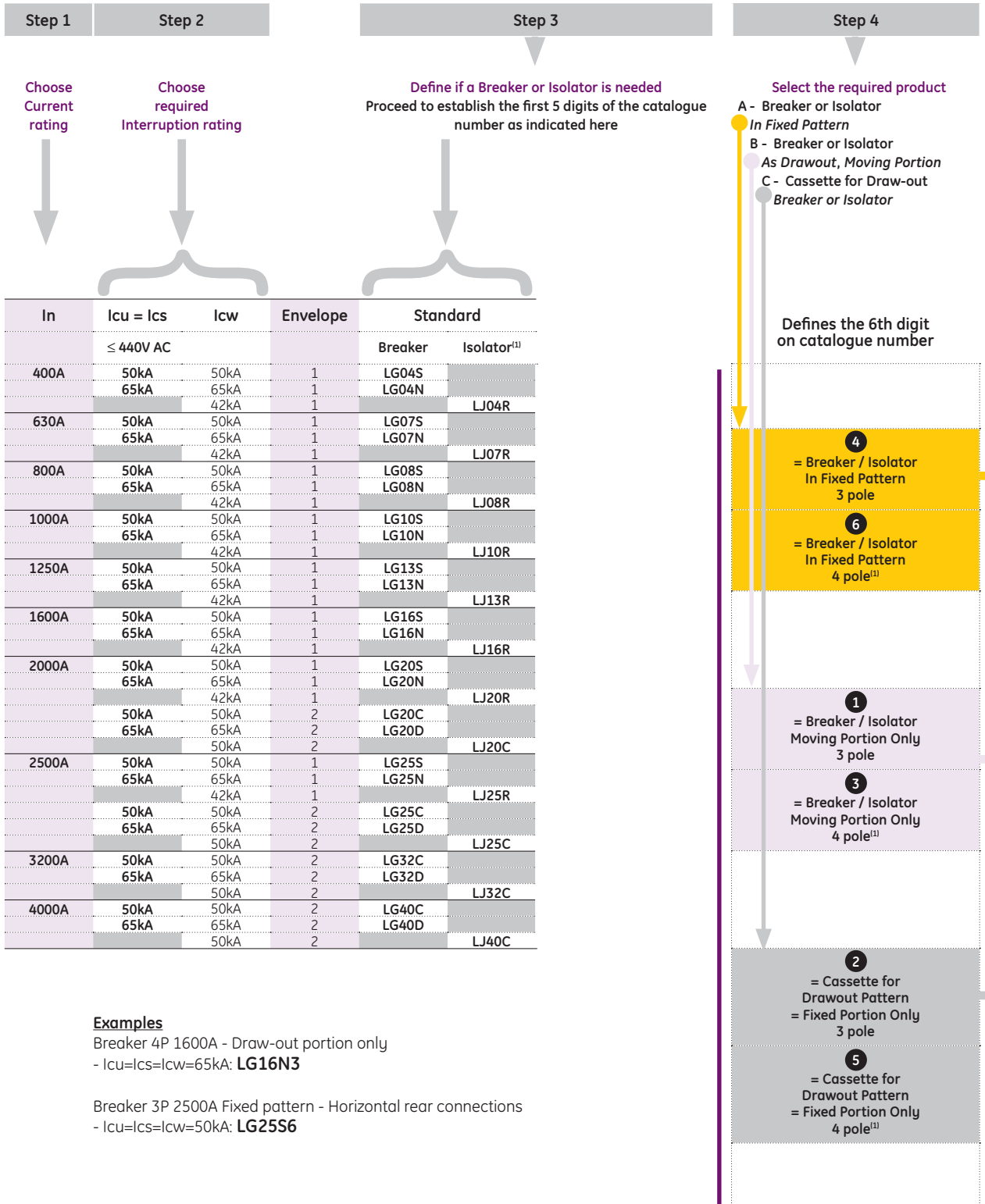

(1) 4 pole Neutral left

Order codes

A

B

C

D

E

X



# in eight simple steps

How to order in eight simple steps

Intro

A

B

C

D

E

X

## Step 5

Finalize the basic catalogue number see catalogue pages:  
 A 4-A.6 - Fixed Pattern  
 A 4-A.6 - Drawout Portion  
 A.5-A.7 - Connections fixed pat.  
 A 5-A.7 - Cassettes, drawout

### Completing the basic catalogue number

No addition  
 Breaker in fixed pattern equipped with RearConnection (Horizontal\*\*), a set of 3NO/3NC aux. Contacts is included

Other options include Rear(Vertical) and Front (Flat) connections

See page A 6 to order Field mountable Adaptation Kits  
 Field mountable

See pages A.4 & A.6

No addition  
 Indicates Breaker / Isolator Moving Portion Only has set of 3NO/3NC aux. Contacts included

See pages A.4 & A.6

**U**  
 = Cassette with Universal 'T stabs' suited for use as Horizontal or Vertical rear connections

**H**  
 = Cassette with Horizontal Rear Connections

**V**  
 = Cassette with Vertical Rear Connections  
 Vertical Rear Connections

**F**  
 = Cassette with Front Flat connections

Safety Shutters always Supplied with Cassette

See page A.5 & A.7

## Step 6

Basic catalogue number is a manually operated device  
**If a Motor Operated device is requested?**  
 Please order  
 Motor and closing coils as Indicated here

### Add catalogue number (s)

If chosen device is a Breaker or Isolator

Envelope 1  
 See page A.9  
 Order a Motor Envelope 1 and 1 Closing Coil Based on voltage Requirements and specifications

If chosen device is a Breaker or Isolator

Envelope 2  
 See page A.9  
 Order a Motor Envelope 2 and 1 Closing Coil Based on voltage Requirements and specifications

## Step 7

If universal internal accessories are needed?  
**Options**  
 UVR or SHT release (s)  
 Auxiliary contacts  
 Alarm & signal contacts

### Add catalogue number (s)

If chosen device is a Breaker or Isolator  
 See page A.9

To add 1 SHT and/or 1 UVR release or two SHT releases.

If chosen device is a Breaker or Isolator  
 See page A.9

To extend on the installed 3 NO + 3NC contacts  
 Maximum of 4 possible

If chosen device is a Breaker or Isolator  
 See page A.9

To add Bell Alarm and/or Ready to close contact

If chosen device is a Cassette  
 See page A.9

If chosen device is a Cassette  
 See page A.9

## Step 8

Full catalogue number defines a Breaker without trip unit.  
**(Isolators do not need trip units)**  
**For all Breakers ADD Trip Unit**

### Add catalogue number (s)

If chosen device is a Breaker  
 See page A.8

Add one of Four Basic Trip units types

#### Offering

An Extremely Large setting range covering Overload, Delayed and Instantaneous Short Circuit Protection and or Groundfault

### - Or -

A 2nd ordering method can be used in which the fully configured breaker or cassette is defined in one character string. This string comprises 18 digits when used for the breaker and 12 for when used for the cassette.

This global ordering code is referred to within GE as the :

### Catalogue Number

It can be defined with stand alone and freely available GE software , is used on all relevant ordering documents and printed on each EntelliGuard breaker front facia. An explanation of this code and it's use can be found on page A.28 of this catalogue.

When ordering with the method indicated here our CRC department will define and confirm the mentioned individual **Catalogue Number**.

Devices ordered here are supplied factory fitted.

Remark : For Other Field Mountable Accessories see page A.11, A.12 & A.13



## Basic breakers executed in a fixed mounting pattern



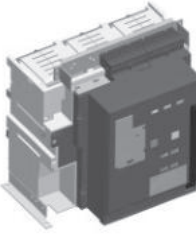
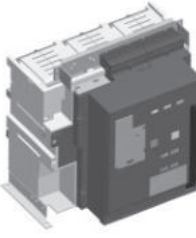
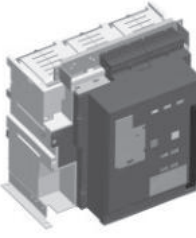

- With Horizontal Rear Connection. (For other options, please refer to page A.7 )
- With auxiliary contact block equipped with 3 NO and 3 NC contacts
- Basic breaker MUST be equipped with a Trip Unit. (Please refer to page A.8 for options)

Order codes

	Rating (A)	3 pole		4 pole <sup>(1)</sup>	
		Cat. No.	Ref. No.	Cat. No.	Ref. No.
 <p><b>S type</b> Icu = Ics = Icw 50kA</p>	400	LG04S4	444066	LG04S6	444100
	630	LG07S4	444067	LG07S6	444101
	800	LG08S4	444068	LG08S6	444102
	1000	LG10S4	444069	LG10S6	444103
	1250	LG13S4	444070	LG13S6	444104
	1600	LG16S4	444071	LG16S6	444105
	2000	LG20S4	444072	LG20S6	444106
	2500	LG25S4	444073	LG25S6	444107
 <p><b>N type</b> Icu = Ics = Icw 65kA</p>	400	LG04N4	444078	LG04N6	444112
	630	LG07N4	444079	LG07N6	444113
	800	LG08N4	444080	LG08N6	444114
	1000	LG10N4	444081	LG10N6	444115
	1250	LG13N4	444082	LG13N6	444116
	1600	LG16N4	444083	LG16N6	444117
	2000	LG20N4	444084	LG20N6	444118
	2500	LG25N4	444085	LG25N6	444119
 <p><b>C type</b> Icu = Ics = Icw 50kA</p>	2000	LG20C4	444074	LG20C6	444108
	2500	LG25C4	444075	LG25C6	444109
	3200	LG32C4	444076	LG32C6	444110
	4000	LG40C4	444077	LG40C6	444111
 <p><b>D type</b> Icu = Ics = Icw 65kA</p>	2000	LG20D4	444086	LG20D6	444120
	2500	LG25D4	444087	LG25D6	444121
	3200	LG32D4	444088	LG32D6	444122
	4000	LG40D4	444089	LG40D6	444123

## Basic breakers: Drawout Breakers; Moving portion only

- With auxiliary contact block equipped with 3 NO and 3 NC contacts
- Basic Breaker MUST be equipped with a Trip Unit. (Please refer to page A.8 for options)
- A cassette is needed, please refer to page A.5 for options

	Rating (A)	3 pole		4 pole <sup>(1)</sup>	
		Cat. No.	Ref. No.	Cat. No.	Ref. No.
 <p><b>S type</b> Icu = Ics = Icw 50kA</p>	400	LG04S1	444000	LG04S3	444033
	630	LG07S1	444001	LG07S3	444034
	800	LG08S1	444002	LG08S3	444035
	1000	LG10S1	444003	LG10S3	444036
	1250	LG13S1	444004	LG13S3	444037
	1600	LG16S1	444005	LG16S3	444038
	2000	LG20S1	444006	LG20S3	444039
	2500	LG25S1	444007	LG25S3	444040
 <p><b>N type</b> Icu = Ics = Icw 65kA</p>	400	LG04N1	444012	LG04N3	444045
	630	LG07N1	444013	LG07N3	444046
	800	LG08N1	444014	LG08N3	444047
	1000	LG10N1	444015	LG10N3	444048
	1250	LG13N1	444016	LG13N3	444049
	1600	LG16N1	444017	LG16N3	444050
	2000	LG20N1	444018	LG20N3	444051
	2500	LG25N1	444019	LG25N3	444052
 <p><b>C type</b> Icu = Ics = Icw 50kA</p>	2000	LG20C1	444008	LG20C3	444041
	2500	LG25C1	444009	LG25C3	444042
	3200	LG32C1	444010	LG32C3	444043
	4000	LG40C1	444011	LG40C3	444044
 <p><b>D type</b> Icu = Ics = Icw 65kA</p>	2000	LG20D1	444020	LG20D3	444053
	2500	LG25D1	444021	LG25D3	444054
	3200	LG32D1	444022	LG32D3	444055
	4000	LG40D1	444023	LG40D3	444056

(1) 4th pole on Left, Trip Unit configurable at 0, 50 or 100% of phase rating



## Termination sets for Breakers & Isolators in fixed pattern

To modify standard connection (horizontal rear) to:

- Vertical rear
- Front flat connection

Sets containing terminals and hardware for the line & load side of the breaker

### Vertical rear connections

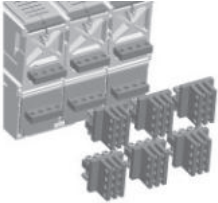

Rating (A)	Suited for use with EntelliGuard -L types	3 pole		4 pole	
		Cat. No.	Ref. No.	Cat. No.	Ref. No.
<i>Terminations for envelope 1</i>					
400 - 1600A	LG version S	L16S4RVI	444441	L16S6RVI	444443
2000 - 2500A	LG version S	L25N4RVI	444445	L25N6RVI	444446
400 - 2500A	LG & LJ versions N & R				
<i>Terminations for envelope 2</i>					
2000 - 3200A	LG & LJ versions C & D	G32M4RVI	408070	G32M6RVI	408071
4000A	LG & LJ versions C & D	G40M4RVI	408072	G40M6RVI	408074

### Front access connections



<i>Terminations for envelope 1</i>					
400 - 1600A	LG version S	L16S4FFI	444440	L16S6FFI	444442
2000 - 2500A	LG version S	L25N4FFI	444444	L25N6FFI	444446
400 - 2500A	LG & LJ versions N & R				
<i>Terminations for envelope 2</i>					
2000 - 3200A	LG & LJ versions C & D	G32M4FFI	408066	G32M6FFI	408068
4000A	LG & LJ versions C & D	G40M4FFI	408067	G40M6FFI	408069

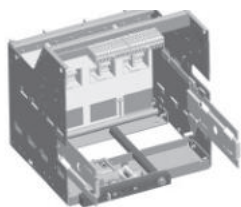

## Cassettes for use with Breakers & Isolators in Drawout pattern

References apply for cassettes supplied in one packaging with Breakers or Isolators (For separate cassettes see page A.12)

- With connection modes as indicated in left column
- Each cassette is supplied with safety shutters

### Horizontal Rear Connections

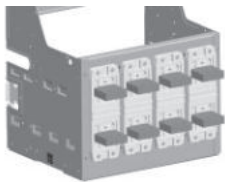

Rating (A)	Suited for use with EntelliGuard -L types	3 pole		4 pole	
		Cat. No.	Ref. No.	Cat. No.	Ref. No.
<i>Cassette for envelope 1</i>					
400 - 1250A	LG version S	LG13S2HM	444272	LG13S5HM	444275
1600A	LG version S	LG16S2HM	444278	LG16S5HM	444281
2000A	LG version S	LG20N2HM	444284	LG20N5HM	444287
400 - 2000A	LG & LJ versions N & R				
<i>Cassette for envelope 2</i>					
2000 - 3200A	LG & LJ versions C & D	LG32D2HM	444289	LG32D5HM	444291
<i>Each cassette is supplied with connection pads for Horizontal connections.</i>					

### Universal rear Connections

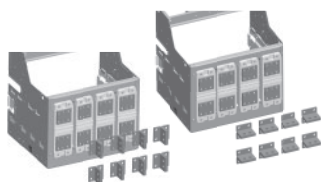

<i>Cassette for envelope 1</i>					
400 - 1250A	LG version S	LG13S2UM	444271	LG13S5UM	444274
1600A	LG version S	LG16S2UM	444277	LG16S5UM	444280
2000 - 2500A	LG version S	LG25N2UM	444283	LG25N5UM	444286
400 - 2500A	LG & LJ versions N & R				
<i>Cassette for envelope 2</i>					
2000 - 3200A	LG & LJ versions C & D	LG32D2UM	444288	LG32D5UM	444290
<i>Each cassette is supplied with connection pads that be rotated and used for Vertical or Horizontal connections.</i>					

### Vertical access Connections



<i>Cassettes for Envelope 2</i>					
4000A	LG & LJ versions C & D	LG40D2VM	444292	LG40D5VM	444293
<i>Each cassette is supplied with Vertical connections.</i>					

### Front Connections



<i>Cassettes for Envelope 1</i>					
400 - 1250A	LG version S	LG13S2FM	444270	LG13S5FM	444273
1600A	LG version S	LG16S2FM	444276	LG16S5FM	444279
2000 - 2500A	LG version S	LG25N2FM	444282	LG25N5FM	444285
400 - 2500A	LG & LJ versions N & R				
<i>Each cassette is supplied with connection pads for front connections.</i>					

## Isolators or Non Automatic breakers executed in a fixed mounting pattern

- With horizontal rear connection. (For other options, please refer to page A.7)
- With auxiliary contact block equipped with 3 NO and 3 NC contacts



	Rating (A)	3 pole		4 pole <sup>(1)</sup>	
		Cat. No.	Ref. No.	Cat. No.	Ref. No.
<b>R type</b> Icw=42kA	400	LJ04R4	444161	LJ04R6	444173
	630	LJ07R4	444162	LJ07R6	444174
	800	LJ08R4	444163	LJ08R6	444175
	1000	LJ10R4	444164	LJ10R6	444176
	1250	LJ13R4	444165	LJ13R6	444177
	1600	LJ16R4	444166	LJ16R6	444178
	2000	LJ20R4	444167	LJ20R6	444179
	2500	LJ25R4	444168	LJ25R6	444180
<b>C type</b> Icw=50kA	2000	LJ20C4	444169	LJ20C6	444181
	2500	LJ25C4	444170	LJ25C6	444182
	3200	LJ32C4	444171	LJ32C6	444183
	4000	LJ40C4	444172	LJ40C6	444184

Order codes

## Isolators or Non Automatic breakers: Drawout Breakers; Moving portion only

- With auxiliary contact block equipped with 3 NO and 3 NC contacts
- A cassette is needed, please refer to page A.7 for options



	Rating (A)	3 pole		4 pole <sup>(1)</sup>	
		Cat. No.	Ref. No.	Cat. No.	Ref. No.
<b>R type</b> Icw=42kA	400	LJ04R1	444135	LJ04R3	444147
	630	LJ07R1	444136	LJ07R3	444148
	800	LJ08R1	444137	LJ08R3	444149
	1000	LJ10R1	444138	LJ10R3	444150
	1250	LJ13R1	444139	LJ13R3	444151
	1600	LJ16R1	444140	LJ16R3	444152
	2000	LJ20R1	444141	LJ20R3	444153
	2500	LJ25R1	444142	LJ25R3	444154
<b>C type</b> Icw=50kA	2000	LJ20C1	444143	LJ20C3	444155
	2500	LJ25C1	444144	LJ25C3	444156
	3200	LJ32C1	444145	LJ32C3	444157
	4000	LJ40C1	444146	LJ40C3	444158

(1) 4th pole on Left, Trip Unit Configurable at 0.50 or 100% of phase rating

Intro

A

B

C

D

E

X





## Termination sets for Breakers & Isolators in fixed pattern

To modify standard connection (horizontal rear) to:

- Vertical rear
- Front flat connection

Sets containing terminals and hardware for the line & load side of the breaker

Vertical rear connections		3 pole		4 pole	
Rating (A)	Suited for use with EntelliGuard L types	Cat. No.	Ref. No.	Cat. No.	Ref. No.
<i>Terminations for envelope 1</i>					
400 - 1600A	LG version S	L16S4RVI	444441	L16S6RVI	444443
2000 - 2500A	LG version S	L25N4RVI	444445	L25N6RVI	444446
400 - 2500A	LG & LJ versions N & R				
<i>Terminations for envelope 2</i>					
2000 - 3200A	LG & LJ versions C & D	G32M4RVI	408070	G32M6RVI	408071
4000A	LG & LJ versions C & D	G40M4RVI	408072	G40M6RVI	408074
<i>Front access connections</i>					
<i>Terminations for envelope 1</i>					
400 - 1600A	LG version S	L16S4FFI	444440	L16S6FFI	444442
2000 - 2500A	LG version S	L25N4FFI	444444	L25N6FFI	444446
400 - 2500A	LG & LJ versions N & R				
<i>Terminations for envelope 2</i>					
2000 - 3200A	LG & LJ versions C & D	G32M4FFI	408066	G32M6FFI	408068
4000A	LG & LJ versions C & D	G40M4FFI	408067	G40M6FFI	408069

## Cassettes for use with Breakers & Isolators in Drawout pattern

References apply for cassettes supplied in one packaging with breakers or isolators (For separate cassettes see page A.12)

- With connection modes as indicated in left column.
- Each cassette is supplied with safety shutters

Horizontal rear connections		3 pole		4 pole	
Rating (A)	Suited for use with EntelliGuard L types	Cat. No.	Ref. No.	Cat. No.	Ref. No.
<i>Cassette for envelope 1</i>					
400 - 1250A	LG version S	LG13S2HM	444272	LG13S5HM	444275
1600A	LG version S	LG16S2HM	444278	LG16S5HM	444281
2000A	LG version S	LG20N2HM	444284	LG20N5HM	444287
400 - 2000A	LG & LJ versions N & R				
<i>Cassette for envelope 2</i>					
2000 - 3200A	LG & LJ versions C & D	LG32D2HM	444289	LG32D5HM	444291
Each cassette is supplied with connection pads for Horizontal connections.					
<i>Universal rear connections</i>					
<i>Cassette for envelope 1</i>					
400 - 1250A	LG version S	LG13S2UM	444271	LG13S5UM	444274
1600A	LG version S	LG16S2UM	444277	LG16S5UM	444280
2000 - 2500A	LG version S	LG25N2UM	444283	LG25N5UM	444286
400 - 2500A	LG & LJ versions N & R				
<i>Cassette for envelope 2</i>					
2000 - 3200A	LG & LJ versions C & D	LG32D2UM	444288	LG32D5UM	444290
Each cassette is supplied with connection pads that be rotated and used for Vertical or Horizontal connections.					
<i>Vertical access connections</i>					
<i>Cassettes for Envelope 2</i>					
4000A	LG & LJ versions C & D	LG40D2VM	444292	LG40D5VM	444293
Each cassette is supplied with Vertical connections.					
<i>Front connections</i>					
<i>Cassettes for Envelope 1</i>					
400 - 1250A	LG version S	LG13S2FM	444270	LG13S5FM	444273
1600A	LG version S	LG16S2FM	444276	LG16S5FM	444279
2000 - 2500A	LG version S	LG25N2FM	444282	LG25N5FM	444285
400 - 2500A	LG & LJ versions N & R				
Each cassette is supplied with connection pads for front connections.					

Intro

A

B

C

D

E

X



GT type Trip Units for Power Circuit Breakers

Order codes

Intro

A

B

C

D

E

X

Factory Mounted Trip Units

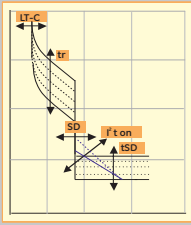
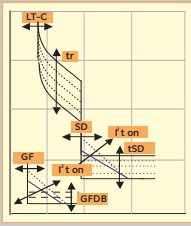
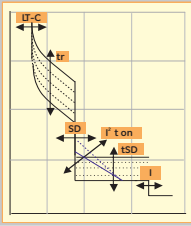
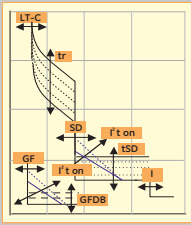
GT-L	Basic functionality	Designation	Cat. No.	Ref. No.
		<b>GT-L Trip Unit with:</b> LT-C 0.4 - 1 x In = Ir tr (22 C type curves) SD I2T ON or OFF tSD (90ms to 1 sec.)	LTG00K1XXSF	444260
		<b>GT-L Trip Unit with:</b> LT-C 0.4 - 1 x In = Ir tr (22 C type curves) SD I2T ON or OFF tSD (90ms to 1 sec.) GF I2T ON or OFF tg (100 ms to 0.9 sec)	LTG00K2XXSF	444261
		<b>GT-L Trip Unit with:</b> LT-C 0.4 - 1 x In = Ir tr (22 C type curves) SD I2T ON or OFF tSD (90ms to 1 sec.) I	LTG00K9XXSF	444262
		<b>GT-L Trip Unit with:</b> LT-C 0.4 - 1 x In = Ir tr (22 C type curves) SD I2T ON or OFF tSD (90ms to 1 sec.) GF I2T ON or OFF tg (100 ms to 0.9 sec) I	LTG00K3XXS	444263

Rogowski coils







For groundfault protection with 3pole breaker in 4 wire networks  
 For use as spares

Sensors	Rating	Envelope 1		Envelope 2	
		Cat. No.	Ref. No.	Cat. No.	Ref. No.
	400A	L104NRC	444420		
	630A	L106NRC	444421		
	800A	L108NRC	444422		
	1000A	L110NRC	444423		
	1250A	L113NRC	444424		
	1600A	L116NRC	444425		
	2000A	L120NRC	444426	L220NRC	444427
	2500A	L125NRC	444428	L225NRC	444429
	3200A			L232NRC	444430
	4000A			L240NRC	444432



## Internal Accessories - Factory mounted

For field mounted variants see page A.11

Motor Operators & Closing Coils <sup>(1)</sup>		Motor Operator Envelope 1		Motor Operator Envelope 2		Closing Coil	
		Cat. No.	Ref. No.	Cat. No.	Ref. No.	Cat. No.	Ref. No.
	24-30V DC	LM01024D	444190	GM01024D	407700	GCCN024D	407861
	110-130V DC	LM01110D	444191	GM01110D	407706	GCCN120	407867
	220V DC	LM01220D	444192	GM01220D	407720	GCCN240	407869
	110-130V AC	LM01120A	444193	GM01120A	407712	GCCN120	407867
	220-240V AC	LM01240A	444194	GM01240A	407714	GCCN240	407869
Releases		Undervoltage		Shunt			
	2V DC	GUVT024D	407795	GSTR024D	407770		
	48V DC; 40-48V AC	GUVT048	407797	GSTR048	407772		
	110-130V AC-DC	GUVT120	407801	GSTR120	407776		
	220-240V AC-DC	GUVT240	407803	GSTR240	407778		
	380-415V AC	GUVT400A	407807	GSTR400A	407782		
Auxiliary Contacts							
	Power Rated 3NO & 3NC	LAS3	444205				
	<i>(Delivered as standard option in all EntelliGuard L breakers &amp; Isolators)</i>						
	Power Rated 4NO & 4NC	LAS4	444206				
Indication Contacts							
	Bell Alarm Contact 1 Change over contact	LBAT1	444207				
	Ready to Closes Contact 1 NO contact	GRIC1	407897				
Position Indication Contacts Cassette							
	1 NO + 1 NC per position	LCPS1	444230				
	2 NO + 2 NC per position	LCPS2	444232				
Locking Mechanisms <sup>(2)</sup>		Ronis		Profalux		Castell 19mm type	
	Mounted on Breaker One Lock can be mounted	LBRON	444212	LBPRO	444211	LBCA9	444214
	Mounted on cassette One Lock can be mounted	LCRON	444216	LCPRO	444215		
Operation Counter							
	On Front Fascia of Breaker Counter; number of Operations	GMCN	408035				

(1) Supplied with spring charged contact  
 (2) See page A.11 for locks

## Internal Accessories - Factory mounted

For field mounted variants see page A.11

Mounted Interlocks for Cables <sup>(1)</sup>							
Type	Interlock scheme			Fixed pattern		Draw-out	
	Brk. 1	Brk. 2	Brk. 3	Cat. No.	Ref. No.	Cat. No.	Ref. No.
A	OFF	OFF		For each Breaker LI2FAD	444221	For each Breaker LI2WAD	444222
	ON	OFF					
	OFF	ON					
B	OFF	OFF	OFF	For each Breaker LI3FB	444223	For each Breaker LI3WB	444224
	ON	OFF	OFF				
	OFF	ON	OFF				
	OFF	OFF	ON				
C	OFF	OFF	OFF	For each Breaker LI3FC	444225	For each Breaker LI3WC	444226
	ON	ON	OFF				
	ON	ON	OFF				
	OFF	ON	ON				
	ON	OFF	ON				
D	OFF	OFF	OFF	For Brk.1 & 3 LI2FAD	444221	For Brk.1 & 3 LI2WAD	444222
	ON	OFF	OFF				
	OFF	OFF	ON	For Brk. 2 LI3FDT	444227	For Brk. 2 LI3WDT	444228
	ON	OFF	ON				

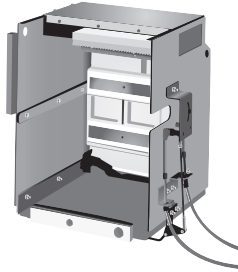

Order codes

## Internal Accessories

Maximum amount of installable internal accessories

Motor Operator type 1 or 2	Closing Coil	Undervoltage Release <sup>(3)</sup>	Shunt Release	Auxiliary contacts NO+NC	Bell Alarm contacts	Ready to Close indication	Spring Charged indication	Carriage Indication Contacts (per Pos.)	Locking Mechanism Breaker	Locking Mechanism Cassette
1	1	1	1	4	1	0	1	2	1	1
1	0	2	1	4	1	0	1	2	1	1
1	1	1	1	4	1	1	0	2	1	1
1	0	2	1	4	1	1	0	2	1	1







(1) These kits are only available FACTORY MOUNTED: On a drawout breaker or isolator the that mechanisms are mounted on the breaker cassette need to be ordered in combination with a breaker and mounted Cassette. For the associated, separately available cables see page A.11.

(2) TDM module (Time delay module) is mounted externally to the breaker.

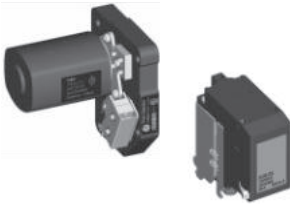

## Internal Accessories - Field mountable

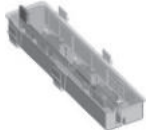
For factory mounted variants see page A.9

	Motor operator envelope 1		Motor operator envelope 2		Closing coil		
	Cat. No.	Ref. No.	Cat. No.	Ref. No.	Cat. No.	Ref. No.	
	24-30V DC	LM01024DR	444195	GM01024DR	407701	GCCN024DR	407860
	110-130V DC	LM01110DR	444196	GM01110DR	407707	GCCN120R	407866
	220V DC	LM01220DR	444197	GM01220DR	407721	GCCN240R	407868
	110-130V AC	LM01120AR	444198	GM01120AR	407713	GCCN120R	407866
	220-240V AC	LM01240AR	444199	GM01240AR	407715	GCCN240R	407868
<b>Releases</b>							
		Undervoltage		Shunt			
	2V DC	GSTR024DR	407796	GSTR024DR	407771		
	48V DC; 40-48V AC	GSTR048R	407798	GSTR048R	407773		
	110-130V AC-DC	GSTR120R	407802	GSTR120R	407777		
	220-240V AC-DC	GSTR240R	407804	GSTR240R	407779		
	380-415V AC	GSTR400AR	407808	GSTR400AR	407783		
<b>Auxiliary contacts</b>							
	Power rated 3NO & 3NC	LAS3R	444208				
	<i>(Delivered as standard option in all EntelliGuard L breakers &amp; Isolators)</i>						
	Power Rated 4NO & 4NC	LAS4R	444209				
<b>Indication contacts</b>							
	Bell alarm contact	LBAT1R	444210				
	1 Change over contact						
<b>Position indication contacts cassette</b>							
	1 NO + 1 NC per position	LCPS1R	444231				
	2 NO + 2 NC per position	LCPS2R	444233				
<b>Locks with random key nr.</b>							
		Ronis		Profalux			
		Cat. No.	Ref. No.	Cat. No.	Ref. No.		
	Ronis 1104 B Lock <sup>(2)</sup>	GRON	407985				
Profalux B204Y Lock <sup>(2)</sup>			GPRO	407986			
<b>Operation counter</b>							
	On Front Fascia of breaker						
	Counter; number of Operations	GMCNR	408033				

(1) Supplied with spring charged contact  
 (2) See page A.9 for lock mechanisms

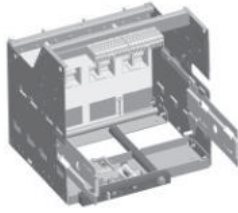

## Cassettes for use with Breakers & Isolators in Draw-out pattern

- References apply for separately supplied cassettes for breakers or isolators (For cassettes supplied with breaker see page A.5)
- With connection modes as indicated in left column
- Each cassette is supplied with safety shutters

### Cassettes for Draw-out Pattern; fixed portion only

Horizontal rear connections		3 pole		4 pole	
Rating (A)	Suited for use with EntelliGuard™ -L types	Cat. No.	Ref. No.	Cat. No.	Ref. No.
<i>Cassettes for Envelope 1</i>					
400 - 1250A	LG version S	LG13S2HR	444302	LG13S5HR	444305
1600A	LG version S	LG16S2HR	444308	LG16S5HR	444311
2000A	LG version S	LG20N2HR	444314	LG20N5HR	444317
400 - 2500A	LG & LJ versions N & R				
<i>Cassettes for Envelope 2</i>					
2000 - 3200A	LG & LJ versions C & D	LG32D2HR	444319	LG32D5UR	444320
Remark: Each cassette is supplied with connection pads for Horizontal connections.					
<i>Universal rear connections</i>					
<i>Cassettes for Envelope 1</i>					
400 - 1250A	LG version S	LG13N2UR	444301	LG13N5UR	444304
1600A	LG version S	LG16N2UR	444307	LG16N5UR	444310
2500A	LG version S	LG25N2UR	444313	LG25N5UR	444316
400 - 2500A	LG & LJ versions N & R				
<i>Cassettes for Envelope 2</i>					
2000 - 3200A	LG & LJ versions C & D	LG32D2UR	444318	LG32D5HR	444321
Remark: Each cassette is supplied with connection pads that be rotated and used for Vertical or Horizontal connections.					
<i>Vertical access connections</i>					
<i>Cassettes for Envelope 2</i>					
4000A	LG & LJ versions C & D	LG40D2VR	444322	LG40D5VR	444323
Remark: Each cassette is supplied with Vertical connections.					
<i>Front connections</i>					
<i>Cassettes for Envelope 1</i>					
400 - 1250A	LG version S	LG13S2FR	444300	LG13S5FR	444303
1600A	LG version S	LG16S2FR	444306	LG16S5FR	444309
2000 - 2500A	LG version S	LG25N2FR	444312	LG25N5FR	444315
400 - 2500A	LG & LJ versions N & R				
Remark: Each cassette is supplied with connection pads for front connections.					
<i>Cassette top covers</i>					
<i>Insulating top covers</i>					
Cassette for Envelope 1		L1CTC1	444450	L1CTC3	444451
Cassette for Envelope 2		L2CTC1	444452	L2CTC3	444453

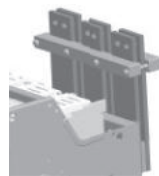
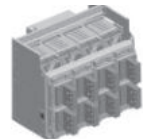
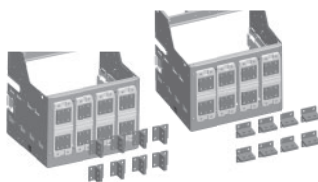
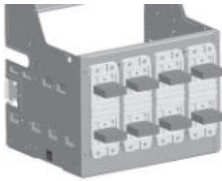

## Accessories - Other

Field mountable cables for interlocking of breakers <sup>(1)</sup>		Interlock scheme		Cat. No.	Ref. No.
Interlock Type	No. of Cables Needed				
	A	1 cable per breaker, choose length as indicated			
	B	1 cable per breaker, choose length as indicated	Cable length 1 metre	GCB1	407990
	C	1 cable per breaker, choose length as indicated	Cable length 1,6 metre	GCB2	407991
			Cable length 2 metre	GCB3	407992
	D	1 cable per breaker, choose length as indicated	Cable length 2,5 metre	GCB4	407993
			Breaker's 1 and 3: Cable length 3 metre	GCB5	407994
			Cable length 3,5 metre	GCB6	407995
Breaker 2: Cable length 4 metre			GCB7	407996	
2 cables choose length as indicated					

  

Time delay module for UVR release type: TDM		Cat. No.	Ref. No.
	110-130V DC	GTDM120D	407819
	220-240V DC	GTDM240D	407821
	110-130V AC	GTDM120A	407818
	220-240V AC	GTDM240A	407820
	380-415V AC	GTDM400A	407824

GT- Accessories		Designation	Cat. No.	Ref. No.
	Power supply 222-265V- AC-24VDC 0.22Amps		GAPU	408789
	Trip unit, sealable transparent front cover		GTUS	408046
	Trip unit tester & No Voltage setup unit		GTUTK20	407999

Locking and Interlocking		Designation		
	<b>Front Fascia of Breaker</b>			
	Padlocking device for Pushbuttons		GPBD	408040
	<b>Cassette</b>			
	Mis insertion device		LREPM	444246
	<b>Door</b>			
	Interlock on LEFT envelope 1		L1LHD	444240
	Interlock on RIGHT envelope 1		L1RHD	444241
	Interlock on LEFT envelope 2		L2LHD	444242
	Interlock on RIGHT envelope 2		L2RHD	444243

(1) See for associated breaker and or cassette mounted kits page A.10

## Spare Parts for Power Circuit Breakers

Order codes

Intro

A







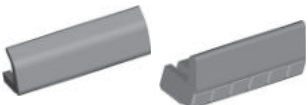

B

C

D

E

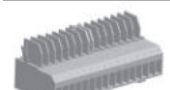
X

	Breaker arc chutes	Envelope 1		Envelope 2	
		Cat. No.	Ref. No.	Cat. No.	Ref. No.
	Arc chute for 1 pole	L25NCHT	444407	L40DCHT	444411
	<b>Breaker fixed arcing contacts</b>				
	Set for 1pole all tiers <sup>(1)</sup>	L25DARC	444404	L40DARC	444410
	<b>Breaker: Door flanges</b>				
	Door flange fixed <sup>(1)</sup>	LDPRF	444200	LDPRF	444200
	Door flange drawout <sup>(1)</sup>	GDPRW	408026	GDPRW	408026
	<b>IP54 cover</b>				
	Front fascia cover IP54	G54DR	408038	G54DR	408038
	<b>Cassette racking handle</b>				
	Racking handle <sup>(1)</sup>	LRHN	444412	LRHN	444412
	<b>Breaker front fascia part<sup>(2)</sup></b>				
	Front fascia 3 or 4 pole <sup>(2)</sup>	LFAL1	444413	LFAL2	444414
	<b>Cassette cluster contacts</b>				
	<b>Sets per pole <sup>(1)</sup></b>				
	Current rating 400-1250A	L13NCLS	444405		
	Current rating 1600A	L16NCLS	444406		
	Current rating 2000-2500A	L25NCLS	444408		
	Current rating 2000-4000A			L40DCLS	444409
	Set of universal cluster pliers	GUNI	408047	GUNI	408047
	<b>Disconnect terminals</b>				
	For fixed or drawour breaker (B & C block 32 pole) (1)	LSDT	444415	LSDT	444415
	<b>Lifting beam</b>				
	Lifting beam for use with standard lifting equipment	GLB1	408045	GLB1	408045

(1) Is a spare, these parts are always supplied with the breaker  
 (2) The original breaker serial number must be indicated on ordering





## Retrofit of existing M-Pact breakers with EntelliGuard L

- Kits applicable for the replacement of complete envelope/frame 1 breakers in a fixed or draw out pattern with cassette.
- Envelope/frame 2 breakers do not require a retrofit kit.
- Allows the use of the existing connection material and fixation holes.
- For the replacement envelope 1 or 2 breaker a new front panel cut out is needed.

Existing Breaker	M-Pact in fixed pattern - Frame 1						
	↓						
Replacement Breaker	EntelliGuard L in fixed pattern - Envelope 1						
	↓						
Replacement kit	S type rating 400-1600A		N type rating 400-1600A		S & N types 2000 & 2500A		
	Cat. No.	Ref. No.	Cat. No.	Ref. No.	Cat. No.	Ref. No.	
3pole 4pole	SMS31F16L16S	444465	SMN31F16L16N	444470	SMN31F25L25N	444475	
	SMS41F16L16S	444466	SMN41F16L16N	444471	SMN41F25L25N	444476	

Existing Breaker	M-Pact in draw-out pattern - Frame 1							
	↓							
Replacement Breaker	EntelliGuard L in draw-out pattern (1) - Envelope 1							
	↓							
Replacement Kit	S type rating 400-1250A		S type rating 1600A		N type rating 400-1600A		S & N types 2000 & 2500A	
					z			
	Cat. No.	Ref. No.	Cat. No.	Ref. No.	Cat. No.	Ref. No.	Cat. No.	Ref. No.
3pole 4pole	SMS31W12L13S	444480	SMS31F16L16S	444485	SMN31W16L16N	444490	SMN31W25L25N	444495
	SMS41W12L13S	444481	SMS41F16L16S	444486	SMN41W16L16N	444491	SMN41W24L25N	444496

## Global Catalogue number structure - Breaker

- Codes built in the indicated manner can be used as an alternative ordering method
- The breaker and its operation mode (manual or electrical)

Order codes

Intro

A

B

C

D

E

X

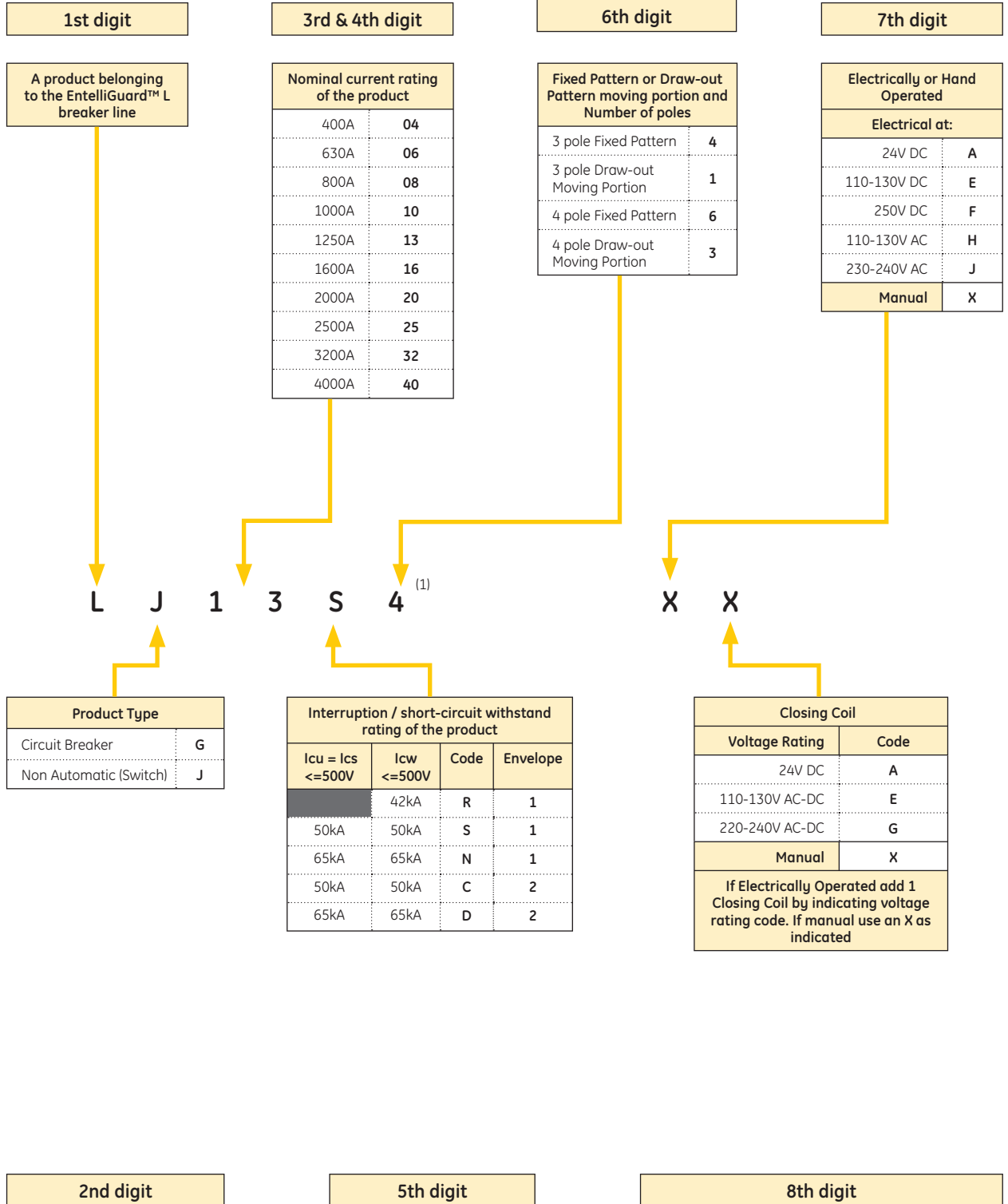

(1) For an overview of the valid combinations indicating the available options see page A.19



## Global Catalogue number structure - Breaker

- Codes built in the indicated manner can be used as an alternative ordering method
- Breaker mounted accessories

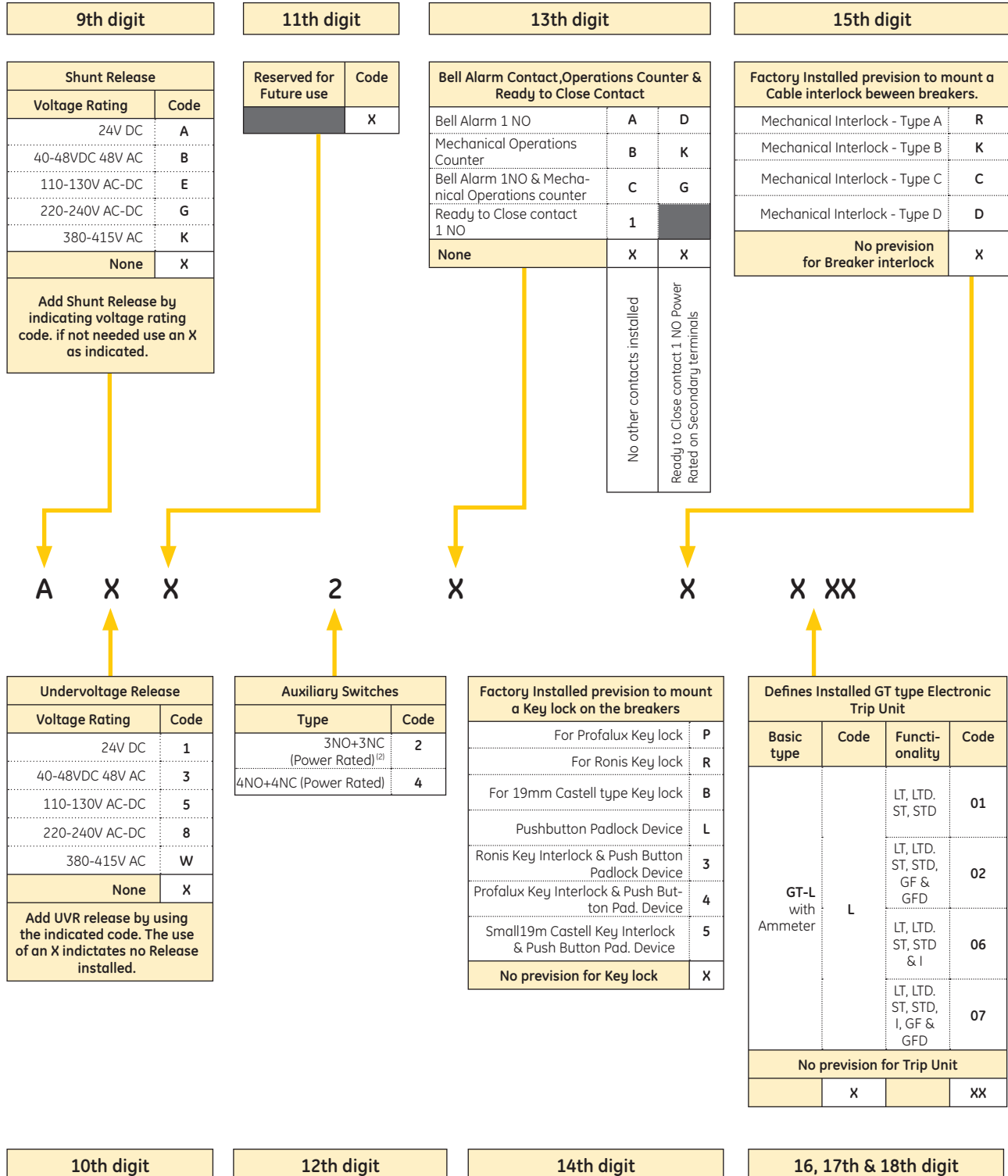

(1) Each standard breaker or Isolator is normally supplied with 3 NO+3NC auxiliary contacts (option 2)



## Global Catalogue number structure - Cassettes

- Codes built in the indicated manner can be used as an alternative ordering method
- Cassettes for uses with drawout breakers

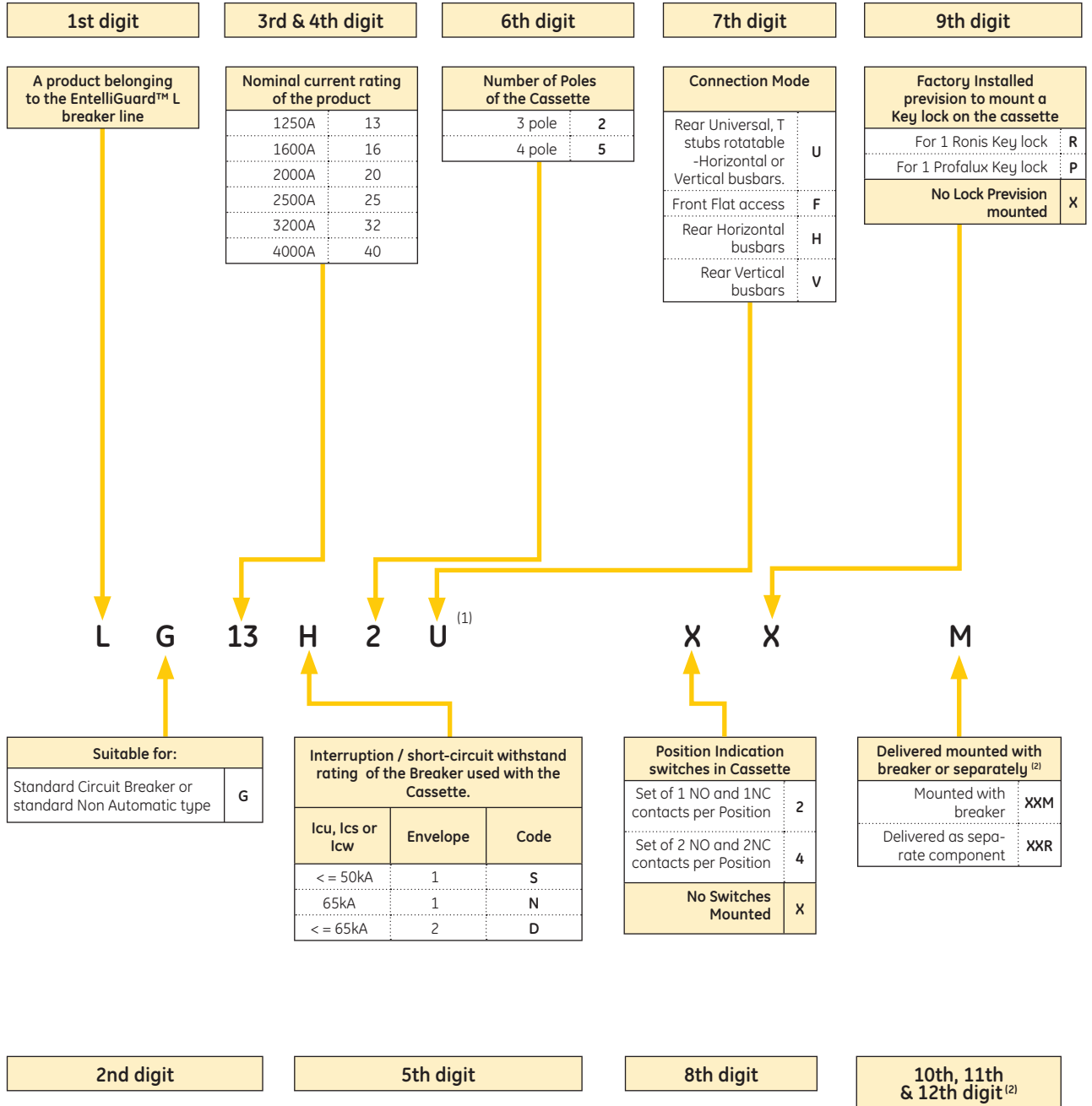

(1) For an overview of the valid combinations indicating the available options see page A.20  
 (2) Digit 10 and 11 are reserved for future use, a filler "XX" is used



## Power Circuit Breakers, Valid Catalogue number combinations

Available standard Breakers, Cassette types and Trip Units

### 3 & 4 pole Breakers and Isolators in Fixed Pattern

Cat. No	Ref. No.	Page
LG04N4	444078	A.4-6
LG04N6	444112	A.4-6
LG04S4	444066	A.4-6
LG04S6	444100	A.4-6
LG07N4	444079	A.4-6
LG07N6	444113	A.4-6
LG07S4	444067	A.4-6
LG07S6	444101	A.4-6
LG08N4	444080	A.4-6
LG08N6	444114	A.4-6
LG08S4	444068	A.4-6
LG08S6	444102	A.4-6
LG10N4	444081	A.4-6
LG10N6	444115	A.4-6
LG10S4	444069	A.4-6
LG10S6	444103	A.4-6
LG13N4	444082	A.4-6
LG13N6	444116	A.4-6
LG13S4	444070	A.4-6
LG13S6	444104	A.4-6
LG16N4	444083	A.4-6
LG16N6	444117	A.4-6
LG16S4	444071	A.4-6
LG16S6	444105	A.4-6
LG20C4	444074	A.4-6
LG20C6	444108	A.4-6
LG20D4	444086	A.4-6
LG20D6	444120	A.4-6
LG20N4	444084	A.4-6
LG20N6	444118	A.4-6
LG20S4	444072	A.4-6
LG20S6	444106	A.4-6
LG25C4	444075	A.4-6
LG25C6	444109	A.4-6
LG25D4	444087	A.4-6
LG25D6	444121	A.4-6
LG25N4	444085	A.4-6
LG25N6	444119	A.4-6
LG25S4	444073	A.4-6
LG25S6	444107	A.4-6
LG32C4	444076	A.4-6
LG32C6	444110	A.4-6
LG32D4	444088	A.4-6
LG32D6	444122	A.4-6
LG40C4	444077	A.4-6
LG40C6	444111	A.4-6
LG40D4	444089	A.4-6
LG40D6	444123	A.4-6
LJ04R4	444161	A.4-6
LJ04R6	444173	A.4-6
LJ07R4	444162	A.4-6
LJ07R6	444174	A.4-6
LJ08R4	444163	A.4-6
LJ08R6	444175	A.4-6
LJ10R4	444164	A.4-6
LJ10R6	444176	A.4-6
LJ13R4	444165	A.4-6
LJ13R6	444177	A.4-6
LJ16R4	444166	A.4-6
LJ16R6	444178	A.4-6
LJ20C4	444169	A.4-6
LJ20C6	444181	A.4-6
LJ20R4	444167	A.4-6
LJ20R6	444179	A.4-6
LJ25C4	444170	A.4-6
LJ25C6	444182	A.4-6
LJ25R4	444168	A.4-6
LJ25R6	444180	A.4-6
LJ32C4	444171	A.4-6
LJ32C6	444183	A.4-6
LJ40C4	444172	A.4-6
LJ40C6	444184	A.4-6

### 3 & 4 pole Breakers and Isolators drawout portion only

Cat. No	Ref. No.	Page
LG04N1	444012	A.4-6
LG04N3	444045	A.4-6
LG04S1	444000	A.4-6
LG04S3	444033	A.4-6
LG07N1	444013	A.4-6
LG07N3	444046	A.4-6
LG07S1	444001	A.4-6
LG07S3	444034	A.4-6
LG07S5	444034	A.4-6
LG08N1	444014	A.4-6
LG08N3	444047	A.4-6
LG08S1	444002	A.4-6
LG08S3	444035	A.4-6
LG08S5	444035	A.4-6
LG10N1	444015	A.4-6
LG10N3	444048	A.4-6
LG10S1	444003	A.4-6
LG10S3	444036	A.4-6
LG10S5	444036	A.4-6
LG13N1	444016	A.4-6
LG13N3	444049	A.4-6
LG13S1	444004	A.4-6
LG13S3	444037	A.4-6
LG13S5	444037	A.4-6
LG16N1	444017	A.4-6
LG16N3	444050	A.4-6
LG16S1	444005	A.4-6
LG16S3	444038	A.4-6
LG16S5	444038	A.4-6
LG20C1	444008	A.4-6
LG20C3	444041	A.4-6
LG20D1	444020	A.4-6
LG20D3	444053	A.4-6
LG20N1	444018	A.4-6
LG20N3	444051	A.4-6
LG20S1	444006	A.4-6
LG20S3	444039	A.4-6
LG20S5	444039	A.4-6
LG25C1	444009	A.4-6
LG25C3	444042	A.4-6
LG25D1	444021	A.4-6
LG25D3	444054	A.4-6
LG25N1	444019	A.4-6
LG25N3	444052	A.4-6
LG25S1	444007	A.4-6
LG25S3	444040	A.4-6
LG25S5	4 44040	A.4-6
LG32C1	444010	A.4-6
LG32C3	444043	A.4-6
LG32D1	444022	A.4-6
LG32D3	444055	A.4-6
LG40C1	444011	A.4-6
LG40C3	444044	A.4-6
LG40D1	444023	A.4-6
LG40D3	444056	A.4-6
LJ04R1	444135	A.4-6
LJ07R1	444136	A.4-6
LJ08R1	444137	A.4-6
LJ10R1	444138	A.4-6
LJ13R1	444139	A.4-6
LJ16R1	444140	A.4-6
LJ20C1	444143	A.4-6
LJ20C3	444155	A.4-6
LJ20R1	444141	A.4-6
LJ25C1	444144	A.4-6
LJ25C3	444156	A.4-6
LJ25R1	444142	A.4-6
LJ32C1	444145	A.4-6
LJ32C3	444157	A.4-6
LJ40C1	444146	A.4-6
LJ40C3	444158	A.4-6

### 3 & 4 pole Cassettes, supplied with breakers

Cat. No	Ref. No.	Page
LG13S2FM	444270	A.5-7
LG13S2HM	444272	A.5-7
LG13S2UM	444271	A.5-7
LG13S5FM	444273	A.5-7
LG13S5HM	444275	A.5-7
LG13S5UM	444274	A.5-7
LG16S2FM	444276	A.5-7
LG16S2HM	444278	A.5-7
LG16S2UM	444277	A.5-7
LG16S5FM	444279	A.5-7
LG16S5HM	444281	A.5-7
LG16N5UM	444280	A.5-7
LG20N2HM	444284	A.5-7
LG20N5HM	444287	A.5-7
LG25N2FM	444282	A.5-7
LG25N2UM	444283	A.5-7
LG25N5FM	444285	A.5-7
LG25N5UM	444286	A.5-7
LG32D2HM	444289	A.5-7
LG32D2UM	444288	A.5-7
LG32D5HM	444291	A.5-7
LG32D5UM	444290	A.5-7
LG40D2VM	444292	A.5-7
LG40D5VM	444293	A.5-7

### 3 & 4 pole Cassettes, supplied separately

Cat. No	Ref. No.	Page
LG13S2FR	444300	A.12
LG13S2HR	444302	A.12
LG13S2UR	444301	A.12
LG13S5FR	444303	A.12
LG13S5HR	444305	A.12
LG13S5UR	444304	A.12
LG16S2FR	444306	A.12
LG16S2HR	444308	A.12
LG16S2UR	444307	A.12
LG16S5FR	444309	A.12
LG16S5HR	444311	A.12
LG16S5UR	444310	A.12
LG20N2HR	444314	A.12
LG20N5HR	444317	A.12
LG25N2FR	444312	A.12
LG25N5FR	444315	A.12
LG25N5UR	444316	A.12
LG25N5UR	444316	A.12
LG32D2HR	444319	A.12
LG32D2UR	444318	A.12
LG32D5HR	444321	A.12
LG32D5UR	444320	A.12
LG40D2VR	444322	A.12
LG40D5VR	444323	A.12

### Trip Units and their accessories

Cat. No	Ref. No.	Page
GAPU	408789	A.14
GTUS	408046	A.14
GTUTK20	407999	A.14
LTG00K1XXSF	444260	A.14
LTG00K2XXSF	444261	A.14
LTG00K3XXS	444263	A.14
LTG00K9XXSF	444262	A.14
L104NRC	444420	A.14
L106NRC	444421	A.14
L108NRC	444422	A.14
L110NRC	444423	A.14
L113NRC	444424	A.14
L116NRC	444425	A.14
L120NRC	444426	A.14
L125NRC	444428	A.14
L220NRC	444427	A.14
L225NRC	444429	A.14
L232NRC	444430	A.14
L240NRC	444432	A.14

**Power Circuit Breakers, Valid Catalogue number combinations**

**Available Accessories**

Order codes

Factory Mounted accessories		
Cat. No	Ref. No.	Page
GCCN024D	407861	A.9
GCCN120	407867	A.9
GCCN120	407867	A.9
GCCN240	407869	A.9
GCCN240	407869	A.9
GM01024D	407700	A.9
GM01110D	407706	A.9
GM01120A	407712	A.9
GM01220D	407720	A.9
GM01240A	407714	A.9
GMCN	408035	A.9
GRTC1	407897	A.9
GSTR024D	407770	A.9
GSTR048	407772	A.9
GSTR120	407776	A.9
GSTR240	407778	A.9
GSTR400A	407782	A.9
GUVT024D	407795	A.9
GUVT048	407797	A.9
GUVT120	407801	A.9
GUVT240	407803	A.9
GUVT400A	407807	A.9
LAS3	444205	A.9
LAS4	444206	A.9
LBAT1	444207	A.9
LBCA9	444214	A.9
LBPRO	444211	A.9
LBRON	444212	A.9
LCPRO	444215	A.9
LCPS1	444230	A.9
LCPS2	444232	A.9
LCRON	444216	A.9
LI2FAD	444221	A.10
LI2FAD	444221	A.10
LI2WAD	444222	A.10
LI2WAD	444222	A.10
LI3FB	444223	A.10
LI3FC	444225	A.10
LI3FDT	444227	A.10
LI3WB	444224	A.10
LI3WC	444225	A.10
LI3WDT	444228	A.10
LM01024D	444190	A.9
LM01110D	444191	A.9
LM01120A	444193	A.9
LM01220D	444192	A.9
LM01240A	444194	A.9

Field Mountable accessories & spares		
Cat. No	Ref. No.	Page
GAPU	408789	A.13
GCB1	407990	A.13
GCB2	407991	A.13
GCB3	407992	A.13
GCB4	407993	A.13
GCB5	407994	A.13
GCB6	407995	A.13
GCB7	407996	A.13
GCCN024DR	407860	A.11
GCCN120R	407866	A.11
GCCN120R	407866	A.11
GCCN240R	407868	A.11
GCCN240R	407868	A.11
GM01024DR	407701	A.11
GM01110DR	407707	A.11
GM01120AR	407713	A.11
GM01220DR	407721	A.11
GM01240AR	407715	A.11
GMCNR	408033	A.11
GPBD	408040	A.13
GPRO	407986	A.11
GREPM	408041	A.13
GRON	407985	A.11
GSTR024DR	407771	A.11
GSTR048R	407773	A.11
GSTR120R	407777	A.11
GSTR240R	407779	A.11
GSTR400AR	407783	A.11
GTDM120A	407818	A.13
GTDM120D	407819	A.13
GTDM240A	407820	A.13
GTDM240D	407821	A.13
GTDM400A	407824	A.13
GTUS	408046	A.13
GTUTK20	407999	A.13
GUVT024DR	407796	A.11
GUVT048R	407798	A.11
GUVT120R	407802	A.11
GUVT240R	407804	A.11
GUVT400AR	407808	A.11
L1CTC1	444450	A.12
L1CTC3	444451	A.12
L1LHD	444240	A.13
L1RHD	444242	A.13
L2CTC1	444452	A.12
L2CTC3	444453	A.12
L2LHD	444241	A.13
L2RHD	444243	A.13
LAS3R	444208	A.11
LAS4R	444209	A.11
LBAT1R	444210	A.11
LCPS1R	444231	A.11
LCPS2R	444233	A.11
LM01024DR	444195	A.11
LM01110DR	444196	A.11
LM01120AR	444198	A.11
LM01220DR	444197	A.11
LM01240AR	444199	A.11
LPBD	444213	A.13

Spare parts		
Cat. No	Ref. No.	Page
G54DR	408038	A.14
GDPRW	408026	A.14
GLB1	408045	A.14
GUNI	408047	A.14
L13NCLS	444405	A.14
L16NCLS	444406	A.14
L25DARC	444404	A.14
L25NCHT	444407	A.14
L25NCLS	444408	A.14
L40DARC	444410	A.14
L40DCHT	444411	A.14
L40DCLS	444409	A.14
LDPRF	444200	A.14
LDPRF	444200	A.14
LFAL1	444413	A.14
LFAL2	444414	A.14
LRHN	444412	A.14
LSDT	444415	A.14

Intro

A

B

C

D

E

X



**Electronic Trip Units**

- B.2 Trip Unit layout & Main menu
- B.3 Overcurrent protection against Overload, LT-C, LTD
- B.4 Trip Unit options and available Long Time current settings
- B.5 Overcurrent protection against Short-circuit: ST, STDB and I<sup>2</sup>t
- B.6 Overcurrent protection against Short-circuit: I, HIOSC and MCR
- B.7 Ground fault protection: GF, GFD', I2T and I4T
- B.8 Electronic Trip Unit features and accessories
- B.9 Time Current curve; LT Overcurrent protection
- B.10 Time Current curve; ST Overcurrent protection
- B.12 Time Current curve; I Overcurrent protection
- B.12 Time Current curve; GF Ground fault protection
- B.14 Time Current curves; Terminology
- B.15 Time Current curves; Example of Full Time Current curve

Air Circuit Breakers

Order Codes

**Electronic Trip Units**

Breaker Accessories

Application Guide

Dimensions

Numerical index

Intro

A

**B**

C

D

E

X



## Electronic Trip Units layout & Main menu



### State of the Art Electronic Trip Unit

EntelliGuard™ L Power Circuit Breakers is equipped with a digital electronic trip unit type GT-L, that has a LCD screen providing an ammeter and a touchpad that allows a simple and accurate menu driven adjustment of the breaker parameters.

All functionality is menu driven accessed by using 4 setting and one enter key thus allowing a fast and accurate setting of the device. These have the following functionality.



- UP: Scroll up, Increment Value
- DOWN: Scroll down, Decrement value
- NEXT function, next page
- PREVIOUS function, previous page
- SAVE setting into memory

In situations where the installation is not yet connected to the power supply and the device needs to be adjusted and have the installed options set the use of the separately available TESTER with Power Pack is advised. (Cat No. GTUTK20)

In Power On situations the Trip Unit display is only functional when the breaker is carrying at least 20% of it's nominal current value. (Single phase)

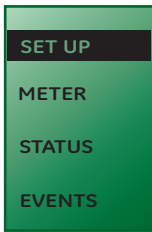

### SET UP MENU

To enter this option begin the process by pressing the UP or DOWN key until SETUP is selected on the screen... Pressing the NEXT or PREVIOUS key allows one to enter the setup mode.

After selecting this mode all functions can be chosen by depressing the NEXT or PREVIOUS key. Within the setup menu all breaker protection values, trip unit parameters, relaying functions in and outputs, communication and trip unit access codes are set.

Each EntelliGuard™ L Electronic trip units provides long-time over-current protection (LT), long-time delay (LTD/ $t_R$ ) and some form of Short Circuit over-current protection (ST and/or I). Optionally Groundfault protection (GFsum) with a delay function (GFDB/ $T_G$ ) can be added.

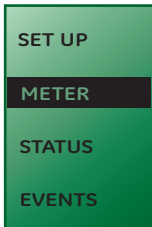

### METER

To enter this option begin the process by pressing the UP or DOWN key until METER is selected on the screen.. Pressing the NEXT or PREVIOUS key allows one to view the current in all three phases and the neutral. The ammeter is only available when the trip unit is powered by the distribution or via the external Testkit.

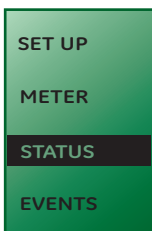

### STATUS

To enter this option begin the process by pressing the UP or DOWN key until METER is selected on the screen. The status option indicates the present status and settings of the trip unit and circuit breaker.



### EVENTS

To enter this option begin the process by pressing the UP or DOWN key until EVENTS is selected on the screen. Pressing the NEXT or PREVIOUS key allows one to access events. Here a total of 10 events with data as, event type and event magnitude are stored. The connection of a 24V DC auxiliary supply to the Trip Unit will expand this option to include a time stamp of each event.

Tripping events as LT, ST, I GF are visualized with the associated levels. It is possible to clear this so called "trip register" locally.



## Overload Protection LT-C and LTD

### Overload (LT-C) Protection

The EntelliGuard™ GT-L Electronic Trip has an extremely accurate and easy to set overload or Long Time (LT-C) Protection. It is designed to pick up overloads that exceed 112% of the set value within two hours with a tolerance of 10% <sup>(1)</sup>.

The device has 15 setpoints distributed over a setting range of 0.4 to 1 times the chosen breaker rating (In)

The LT-C type is designed to be used in association with down- and upstream circuit breakers and has a so called I<sup>2</sup>t shape producing a curve form similar to standard industrial thermal magnetic protection devices.

The Time-Current protection curve depicted here is drawn in cold state. A cooling function in the device corrects for the heating of the connected lines and equipment.

In order to allow an accurate adjustment to the thermal properties of the protected equipment and to finely match the curve with those of Upstream & Downstream devices 22 time bands are available.

The table indicates the minimum delay time and maximum total interruption times for 3 frequently used reference points on the curve of each band. The graph portrays the LT behaviour for the time-current bands C-4, C-8, C-13 & C-22.

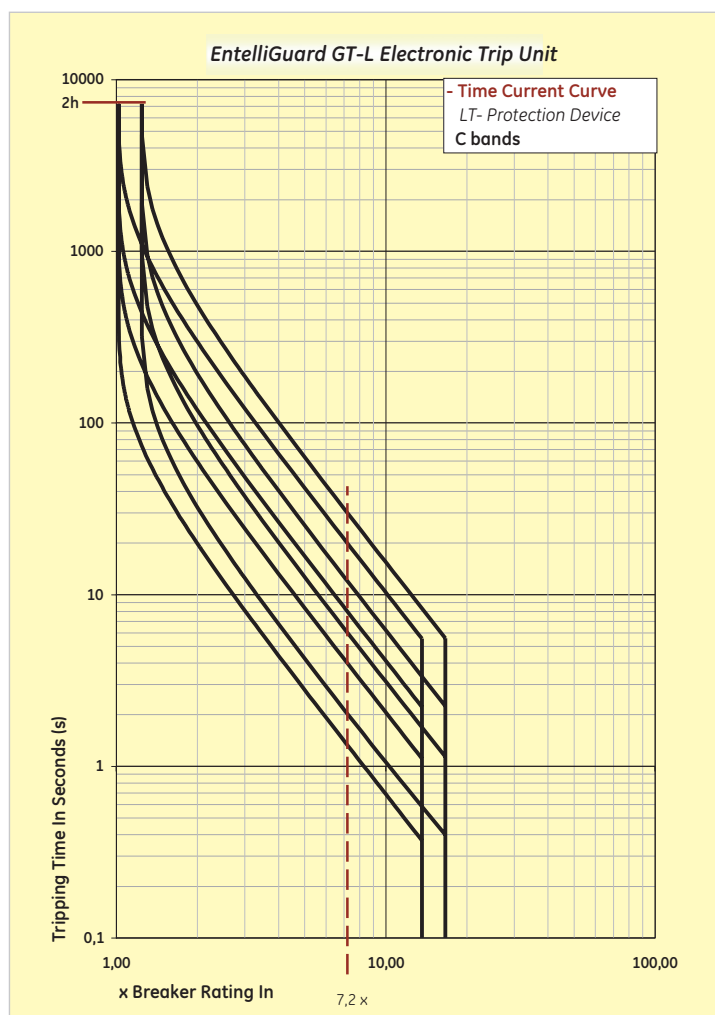
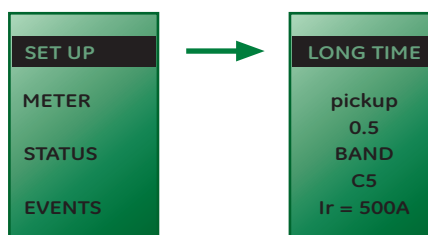

Overload Tripping times at indicated overload levels per selected LTD band, in Seconds

xIr	Cmin	C-2	C-3	C-4	C-5	C-6	C-7	C-8	C-9	C-10	C-11	C-12	C-13	C-14	C-15	C-16	C-17	C-18	C-19	C-20	C-21	Cmax	
1.5	Max.	7,8	23,4	46,7	62,3	93,4	125	156	187	218	249	280	311	374	436	498	560	623	685	747	810	872	934
	Min.	4,0	12,0	24,0	32,0	48,0	64,1	80,1	96,1	112	128	144	160	192	224	256	288	320	352	384	416	448	480
3	Max.	1,3	3,86	7,73	10,3	15,5	20,6	25,8	30,9	36,1	41,2	46,4	51,5	61,8	72,1	82,4	92,7	103	113	124	134	144	155
	Min.	0,80	2,41	4,82	6,43	9,64	12,9	16,1	19,3	22,5	25,7	28,9	32,1	38,6	45,0	51,4	57,8	64,3	70,7	77,1	83,6	90,0	96,4
7.2	Max.	0,21	0,62	1,24	1,66	2,49	3,32	4,15	4,98	5,81	6,64	7,47	8,30	9,96	11,6	13,3	14,9	16,6	18,3	19,9	21,6	23,2	24,9
	Min.	0,13	0,40	0,81	1,07	1,61	2,15	2,69	3,22	3,76	4,30	4,83	5,37	6,45	7,52	8,60	9,67	10,7	11,8	12,9	14,0	15,0	16,1
<b>Motor Protection Class to IEC 947-4</b>							<b>10b</b>			<b>10</b>			<b>20</b>			<b>30</b>			<b>40</b>				

(1) Meeting the requirements of IEC 90647-2 and IEC 90647-4

## Trip Unit Functionality & available Long Time settings

Trip Unit functionality		GT-L
Setting interface	LCD Screen allowing access to 4 distinct menu's	X
	Touch pad adjustments	X
	Multilingual	X
	Adjustable manual or automatic RESET option	X
Long time or overload current protection	I <sub>r</sub> =0.4 to 1In 15 secondary current settings	X
	22 Thermal Protection (C type) time bands available ranging from class 0.5 to 40 (bands at 7.2 x I <sub>r</sub> )	X
	Neutral Protection 0-50%-63%-100%	X
	Cooling function and Thermal memory	X
Short time short-circuit current protection	Setting range from <b>1.5 to 12</b> x I <sub>r</sub> (LT setting)	X
	Steps of 0.5 (A total of 22 settings)	X
	17 time delay settings ( <b>STDB</b> ) ranging from 30 to 940 milliseconds delay setting result in a 90 to 1000 milliseconds clearing time	X
	Clearance times to IEC 40979-1 and IEC 60364	X
	3 I <sup>2</sup> t Protection time bands available	X
Instantaneous Short-circuit Current Protection	I <sub>i</sub> setting range from <b>2 to 15</b> x I <sub>n</sub>	X
	Steps of 0.5 (A total of 28 settings)	X
	Possibility to switch <b>OFF</b>	X
	<b>Selective execution</b>	X
	Fixed instantaneous or HSI OC protection	X
Ground Fault Protection	Setting range from <b>0.2 to 1</b> x I <sub>n</sub> (Breaker rating)	O
	Steps of 0.01 (A total of 92 settings)	O
	Possibility to switch <b>OFF</b>	O
	14 time delay settings ( <b>GFDB</b> ) ranging from 50 to 840 milliseconds delay setting resulting in a 110 to 900 milliseconds clearing time	O
	Clearance times to IEC 40979-1 and IEC 60364	O
	3 I <sup>2</sup> t protection time bands available	O
	Residual principle	O
Data Acquisition & Diagnostics	Trip Target (trip reason indication)	X
	Trip Info (Magnitude / Phase)	X
	Trip Counter	X
	Event Logger (trip events)	X
	Good & Bad Health Indicator	X
Other	24V DC Auxiliary power supply	O
	Test kit with power support function	O

**Key:**  
 X = Present  
 O = Optional

Trip Unit LT settings					
Breaker In (A)	400	630	800	1000	1250
GT-L Setting x I <sub>n</sub>	Available Setpoints (A)				
0,4	160	252	320	400	500
0,45	180	284	360	450	563
0,5	200	315	400	500	625
0,55	220	347	440	550	688
0,6	240	378	480	600	750
0,65	260	410	520	650	813
0,7	280	441	560	700	875
0,75	300	473	600	750	938
0,8	320	504	640	800	1000
0,75	300	473	600	750	938
0,8	320	504	640	800	1000
0,85	340	536	680	850	1063
0,9	360	567	720	900	1125
0,95	380	599	760	950	1188
1	400	630	800	1000	1250

Trip Unit LT settings					
Breaker In (A)	1600	2000	2500	3200	4000
GT-L Setting x I <sub>n</sub>	Available Setpoints (A)				
0,4	640	800	1000	1280	1600
0,45	720	900	1125	1440	1800
0,5	800	1000	1250	1600	2000
0,55	880	1100	1375	1760	2200
0,6	960	1200	1500	1920	2400
0,65	1040	1300	1625	2080	2600
0,7	1120	1400	1750	2240	2800
0,75	1200	1500	1875	2400	3000
0,8	1280	1600	2000	2560	3200
0,75	1200	1500	1875	2400	3000
0,8	1280	1600	2000	2560	3200
0,85	1360	1700	2125	2720	3400
0,9	1440	1800	2250	2880	3600
0,95	1520	1900	2375	3040	3800
1	1600	2000	2500	3200	4000



## Short-circuit Protection ST and STDB

### Overcurrent Protection against short-circuit: ST, STDB

The EntelliGuard™ GT-L Electronic Trip and breaker combination can be equipped with a number of different short-circuit protection devices each with their own distinctive properties and field of application.

The Timed Short-circuit Protection Device is designed to offer selectivity over a defined current range and offers a unique combination of multiple time bands and current settings.

To allow selectivity with a wide range of different downstream devices whilst not unnecessarily sacrificing clearing time, 17 different time bands are available. The device has an adjustment range of 1.5 to 12 (+-10%) times the chosen Long Time current value (I<sub>r</sub>) in steps of 0,5 (pick up setting).

The graph indicates 6 of the available 17 time bands across the full adjustment range. The table contains the minimum delay time and the maximum total interruption times for all time band settings.

### Timed Short-circuit (ST) Protection I<sup>2</sup>t bands (slope)

The ST device can also be set to a I<sup>2</sup>t slope value. The available multiple I<sup>2</sup>t slopes are normally used to achieve selectivity with downstream fuses or to improve selectivity with downstream circuit breakers.

The device has an adjustment range of 1.5 to 12 (+-10%) times the chosen Long Time current value (I<sub>r</sub>) in steps of 0.5 (pick up setting) and 17 time bands.

There are three available I<sup>2</sup>t slopes (K set at 3,8 or 18).

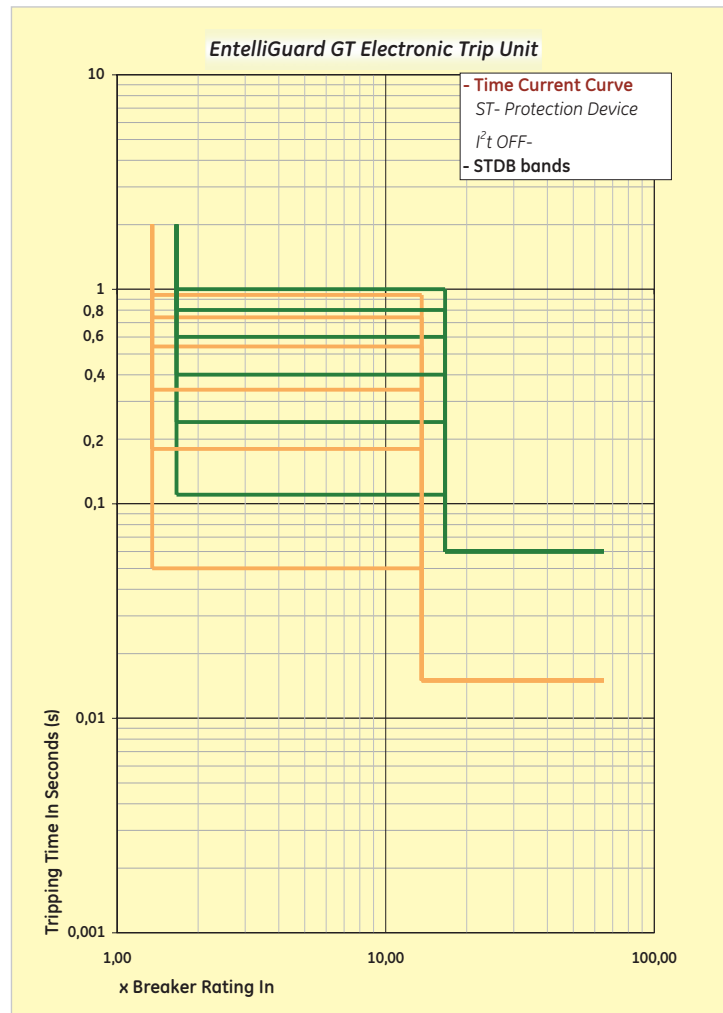
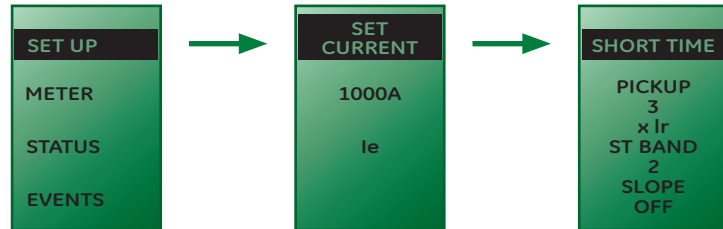

Short time tripping times at indicated levels per selected STDB band - I<sup>2</sup>t OFF, in milliseconds

	x I <sub>r</sub>	Min	2	3	4	5	6	7	8	9	10	11	12	13	14	15	16	Max
1.5 x ±10%	Tripping	90	100	110	120	170	190	240	270	300	340	400	450	600	700	800	900	1000
	Non Tripping	30	40	50	60	110	130	180	210	240	280	340	390	540	640	740	840	940
12 x ±10%	Tripping	90	100	110	120	170	190	240	270	300	340	400	450	600	700	800	900	1000
	Non Tripping	30	40	50	60	110	130	180	210	240	280	340	390	540	640	740	840	940

## Short-circuit Protections, I, HIOSC & MCR

### Instantaneous Short-circuit (I) Protection

A user settable device that allows a high speed fault interruption at a pre-determined current level. This device can be used with the short time delayed (ST) short-circuit protection device or as replacement thereof. The device has a current adjustment of 2 to 15 ( $\pm 10\%$ ) times the chosen Primary Current Value ( $I_e$ ) in steps of 0.5. The device can also be switched OFF. On breakers with a rating of more than 4000A the maximum setting of 15 x is in some cases limited to a lower value due to the breaker current rating and its Short-circuit withstand value (see page B.11). The Instantaneous tripping system used in the EntelliGuard Electronic Trip Unit has a unique programming feature that waits for the downstream device to trip before reacting to an overcurrent fault. This providing the user with a unique combination of **Speed** and **Selectivity**.

*The graph indicates the maximum interruption time and non tripping time across the full current setting band and the transition to the HIOS protection device.*

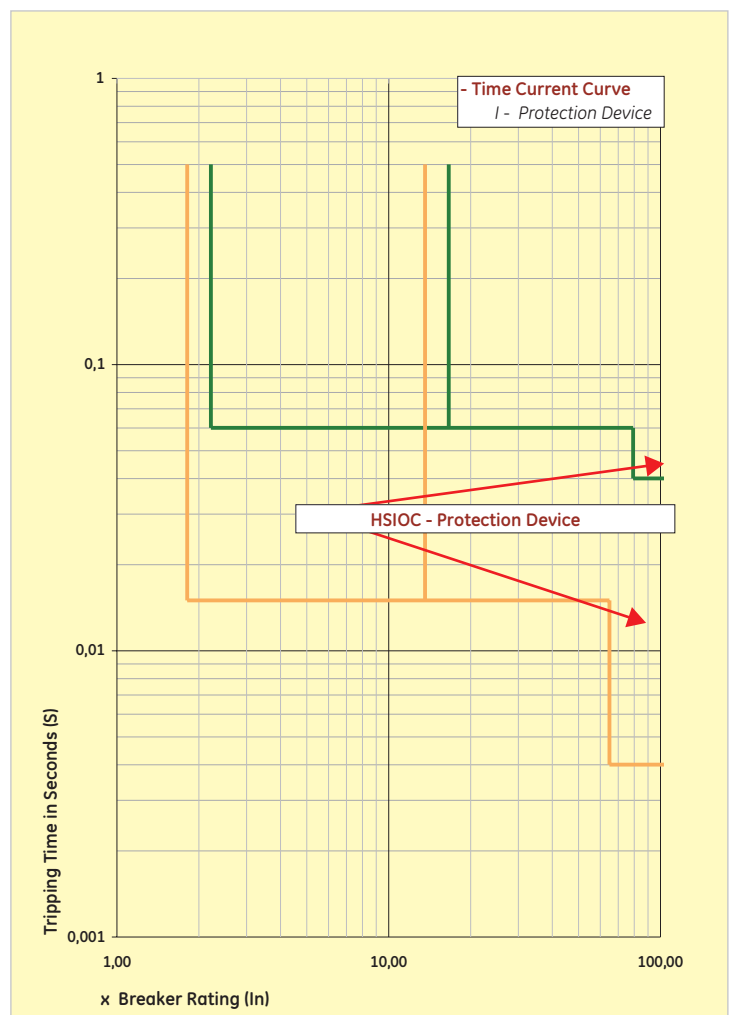
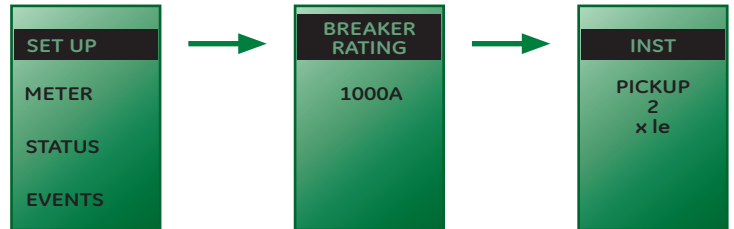

### HSIOC Protection device

To prevent very high level short-circuit currents causing damage to their electrical installation and their components EntelliGuard Power Circuit Breaker are equipped with a HSIOC protection device.

This high level short-circuit device is installed in all EntelliGuard L Breakers and is designed to trip the breaker at the specified  $I_{cw}$  value of the device. The device, interrupts and thus limits the duration of these high level short-circuits to 40 milliseconds.

### Making Current (MCR) Protection device

If a breaker is closed on to a short-circuit current it is mandatory that the device interrupts before the electrical installation and its components incur any damage.

An MCR device is present in all EntelliGuard Power Circuit Breakers specifically designed to trip the breaker when closing onto a fault.

## Ground Fault Protections GF & GFD

### Ground Fault Protection (GFsum)

To protect an installation or a part thereof against indirect contact, Protection Devices can be used to automatically disconnect the power supply when a fault to earth is detected. The HD384 installation standard requires that the mentioned device senses the fault and then interrupts the supply within a specified time frame.

A short-circuit device as an EntelliGuard Power Circuit Breaker can be used to meet this requirement. However these short-circuit protection devices are normally set at values that are too high to detect normally occurring faults to Earth.

The optionally available Ground Fault protection feature is specifically designed to detect lower currents than a standard short-circuit Device and operate by residually summing the current in the Phases and Neutral. When a fault to Earth creates an unbalance in the system the resulting Fault Current is detected by the device that produces an alarm signal or trips the associated circuit breaker thus disconnecting the circuit.

The EntelliGuard Ground fault device has an adjustment range of 0.2 to 1 (±15%) times the chosen breaker rating (In) and can be set in steps of 0,01 (pick up setting). To allow selectivity with other downstream protection devices there are 14 different time band settings available.

The graph indicates a number of the available 14 time bands across the full adjustment range. The table contains the minimum delay time and the maximum total interruption times for all time band settings.

The Ground fault device must monitor the current in all phases and the Neutral. When a 3 pole device is used in a 4 wire (3phase + Neutral) system a 4th sensor must be placed in the Neutral. On use of a 4 pole EntelliGuard breaker the sensor is already present in the Neutral pole.

### Ground Fault Protection I<sup>2</sup>t or I<sup>4</sup>t bands (slope)

The GF device can also be set to a slope value. The available multiple I<sup>2</sup>t and I<sup>4</sup>t slopes are normally used to achieve selectivity with downstream fuses or to improve selectivity with downstream circuit breakers.

The user has the possibility to choose a current adjustment of 0.2 to 1 (times the chosen breaker rating (In) in steps of 0.01 and one of 14 time bands.

There are three available slopes: Low, Medium and High.

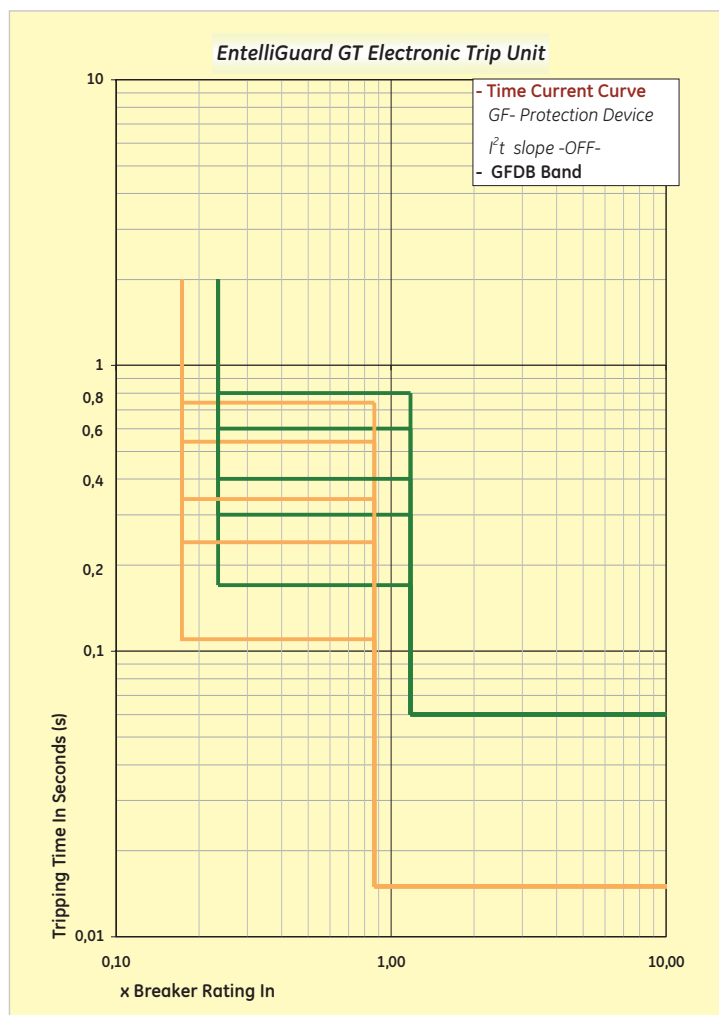
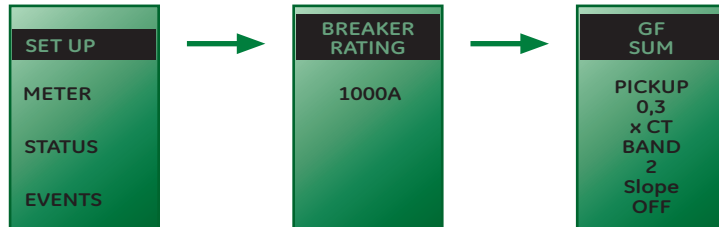

Ground fault tripping times at indicated levels per selected GFDB band -I<sup>2</sup>t slope OFF, in milliseconds

	x Ir	1	2	3	4	5	6	7	8	9	10	11	12	13	14
0.2 x	Tripping	110	120	140	170	190	240	270	340	400	450	600	700	800	900
±10%	Non Tripping	50	60	80	110	130	180	210	280	340	390	540	640	740	840
0.6 x	Tripping	110	120	140	170	190	240	270	340	400	450	600	700	800	900
±10%	Non Tripping	50	60	80	110	130	180	210	280	340	390	540	640	740	840

## Measurement Functions and Power Supplies

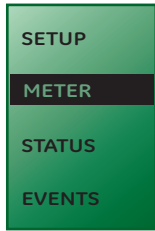

### Ammeter

An Ammeter is supplied with each EntelliGuard™ Electronic Trip Unit. The current in each of the three phases and the Neutral can be viewed.

The device has an accuracy of 2% when viewed at the nominal current of the breaker and an accuracy of 5% when viewed when the breaker is running at 50 - 85% of its full load.

Parameter	Measured	Units	Resolution	Accuracy at 100% of breaker rating
Current	L1, L2, L3, N	A	0000	2%

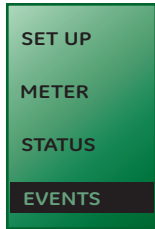

### Trip Reason Indicators (event logging) Trip Operations counter.

The Electronic Trip Unit keeps track of data indicating why the associated breaker has tripped and on how many occurrences have taken place. Accessible under the 'EVENTS' menu the Trip Reason Indicator keeps track of a maximum of 10 events that have caused the EntelliGuard breaker to trip. The device stores the voltage, the phase's involved, the current value, the reason of the trip and the trip number (see counter). When an auxiliary voltage is connected the time and date of the event are also stored.

Accessible under the 'STATUS' menu the Trip Operations Counter registers a maximum of 255 overcurrent faults with their reason. (LT, ST, I or GF-EF). The data can be viewed and reset through the STATUS menu Pickup status option.

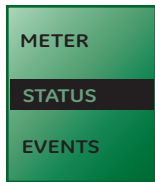

### Neutral Protection

When inserted into a 4 pole breaker the EntelliGuard™ Electronic Trip Unit senses that the breaker in which the device is installed has a Neutral Pole. Via the set Up menu, a Neutral Setting option then becomes available in which the

LT, ST and I protection device can be jointly set to one of the following values: **0%, 50%, 63% or 100%. x the values set for the phase protection device.**

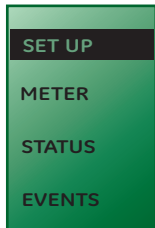

### Reset Choice Function

When a fault has occurred the Trip Unit trips the associated breaker. It is then deemed normal installation practise to verify the reason of the fault before reconnecting power by resetting and switching the breaker on. The advanced options included in the EntelliGuard™ Trip Unit provide the user with the fault reason, magnitude and location, thus allowing the user to easily establish the

required corrective actions. To follow this procedure Trip Unit reset function should be set to MANUAL. However, in some cases it is required that the breaker resets itself automatically. If this functionality is required, the reset function should be set to AUTOMATIC. A selector switch on the Trip Unit front face allows the user this choice.



### Auxiliary Power Supply

The 24V DC auxiliary supply allows of the trip unit setup function when the standard supply is disconnected. At circuit loads >20% the standard power supply allows full uses of the setup option.

The separately available Test Box Kit can also be used as a temporary power supply. This device has a battery pack and optionally can provide power by using a 24 V DC power supply.

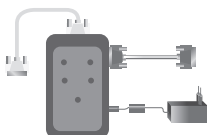

### Test Kit

To verify that the Electronic Trip Unit is interfacing correctly with the Breaker and to establish if the circuitry in the Trip Unit is functioning correctly a test kit is available.

The device has a 24V auxiliary supply to allow it's use in a secondary function as power supply of the Trip unit when no network power supply is available. The device can be plugged in to a jack on the trip Unit Front face.



## Time Current Curves (cold state)

LT Protection Device

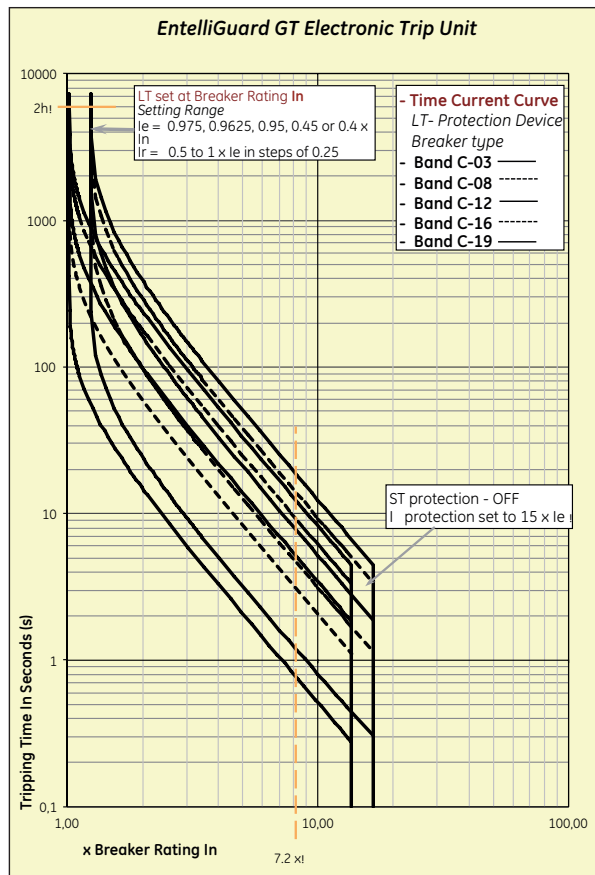
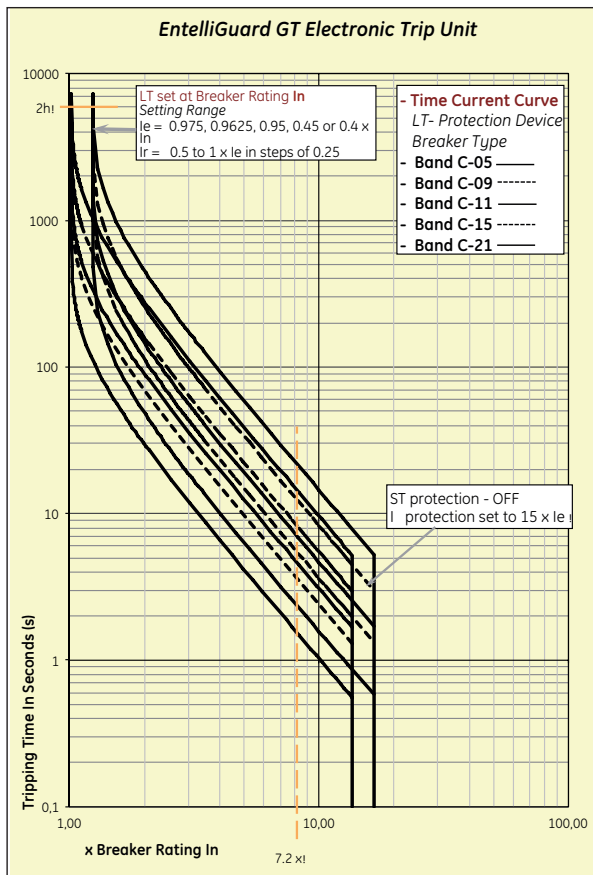
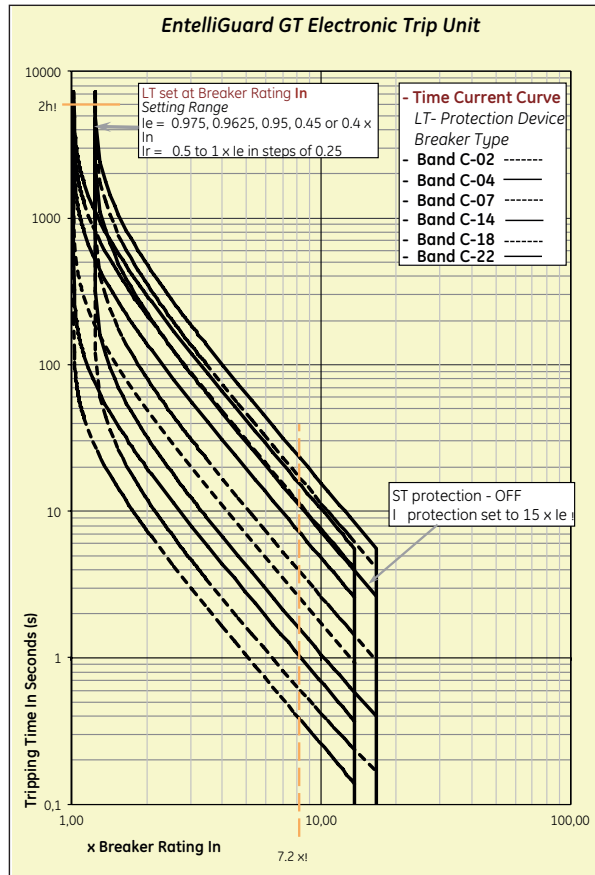
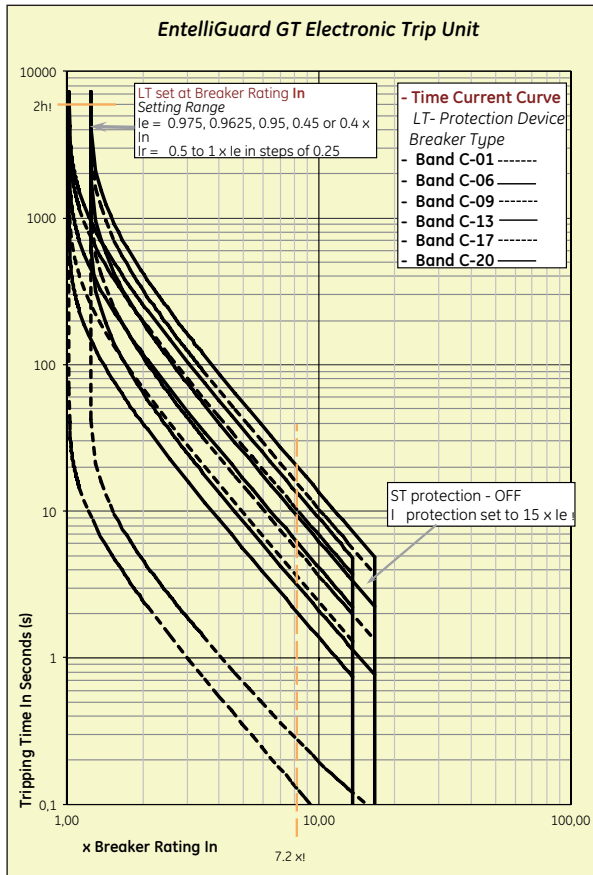

## Time Current Curves (cold state)

ST Protection Device

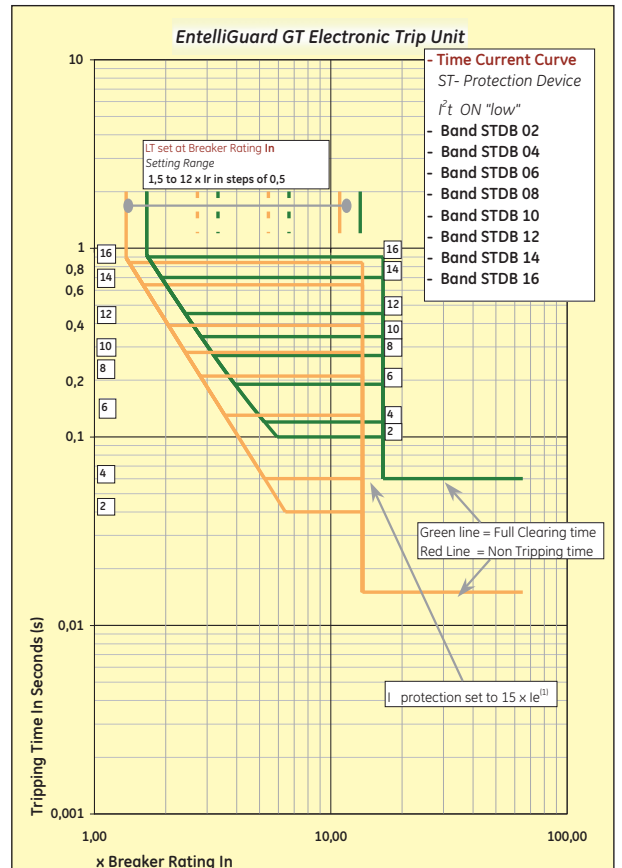
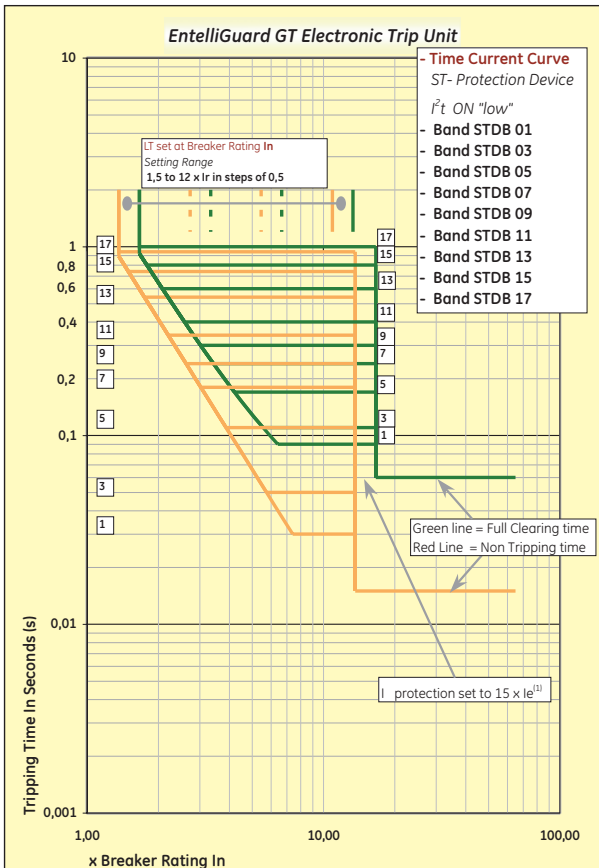
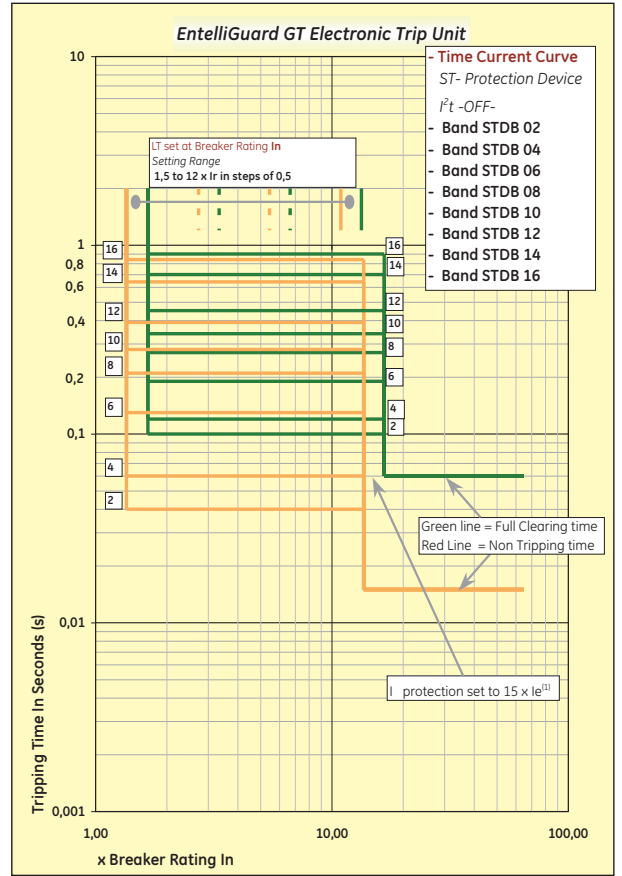
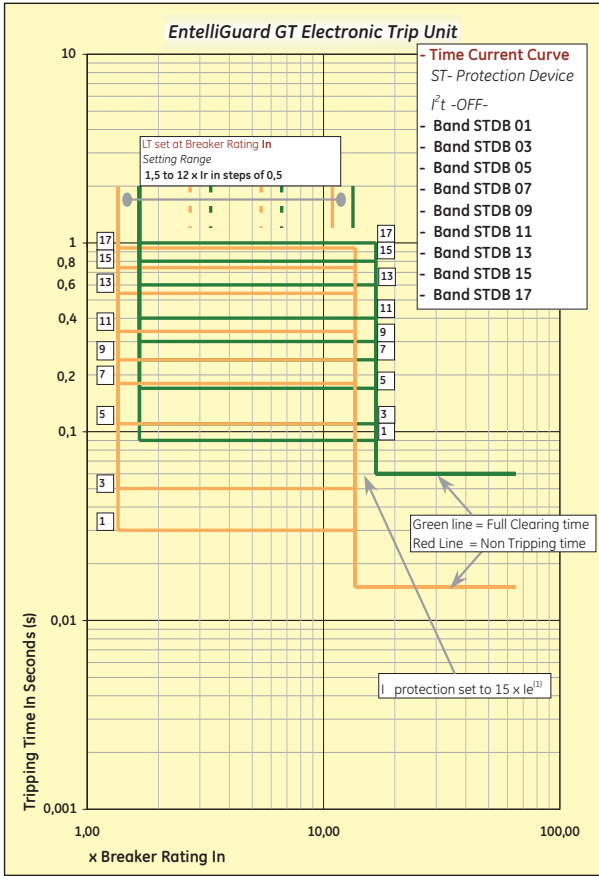



## Time Current Curves (cold state)

ST Protection Device

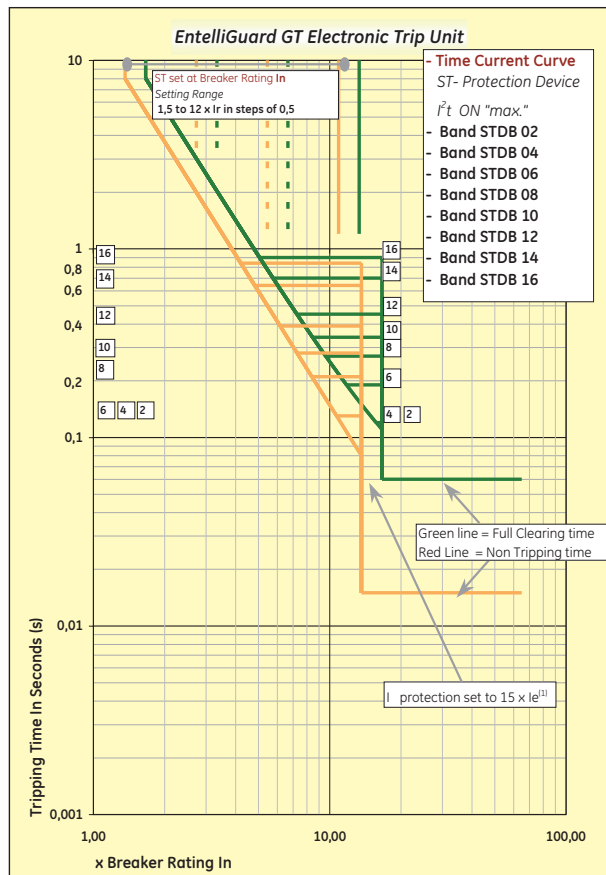
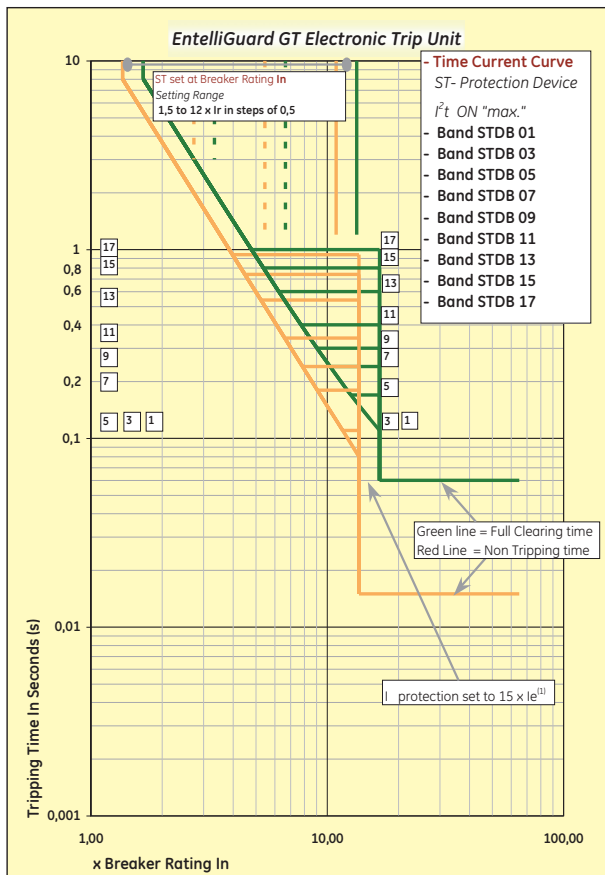
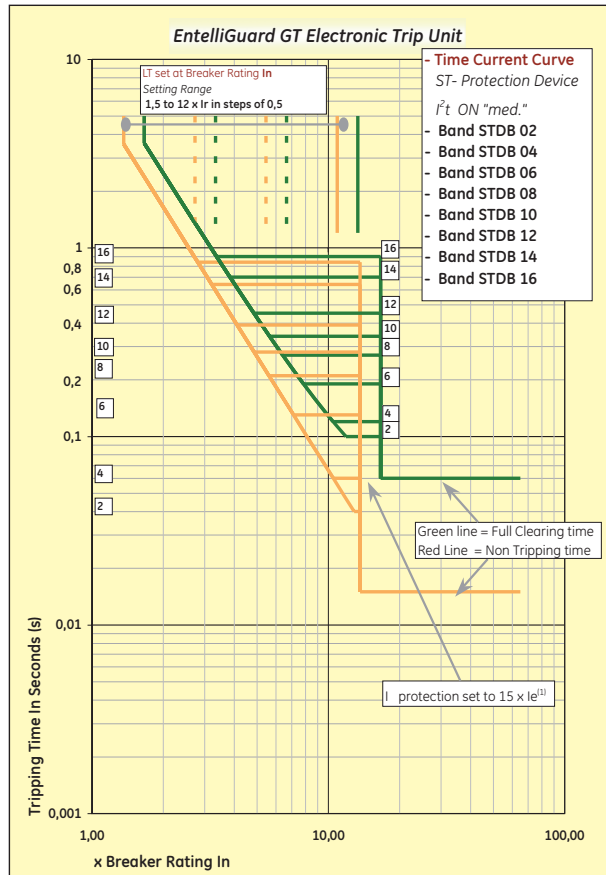
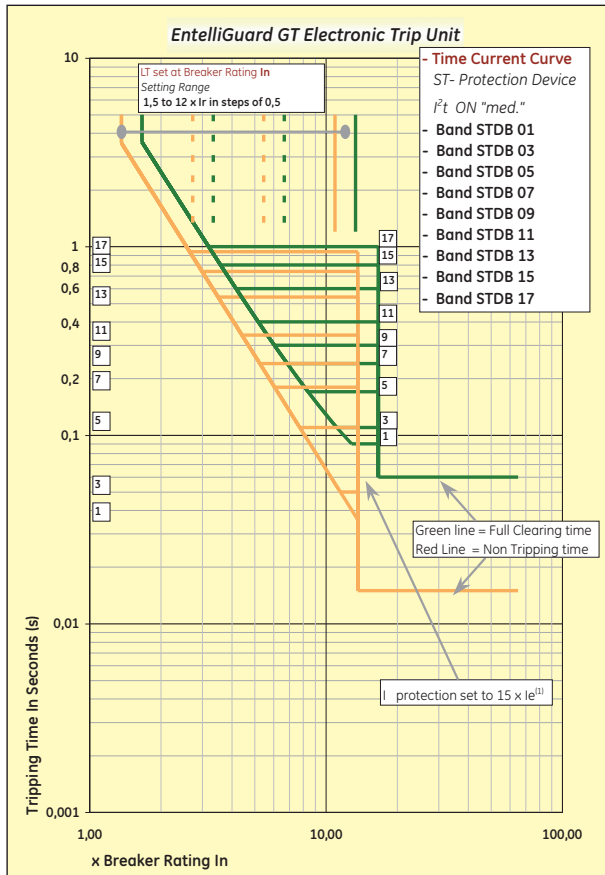

## Time Current Curves (cold state)

I & GF Protection Device

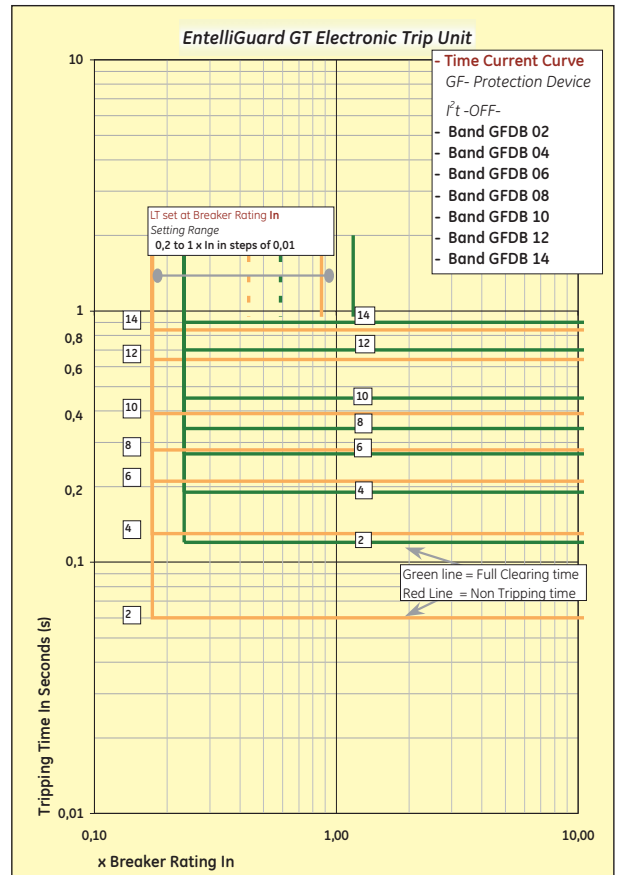
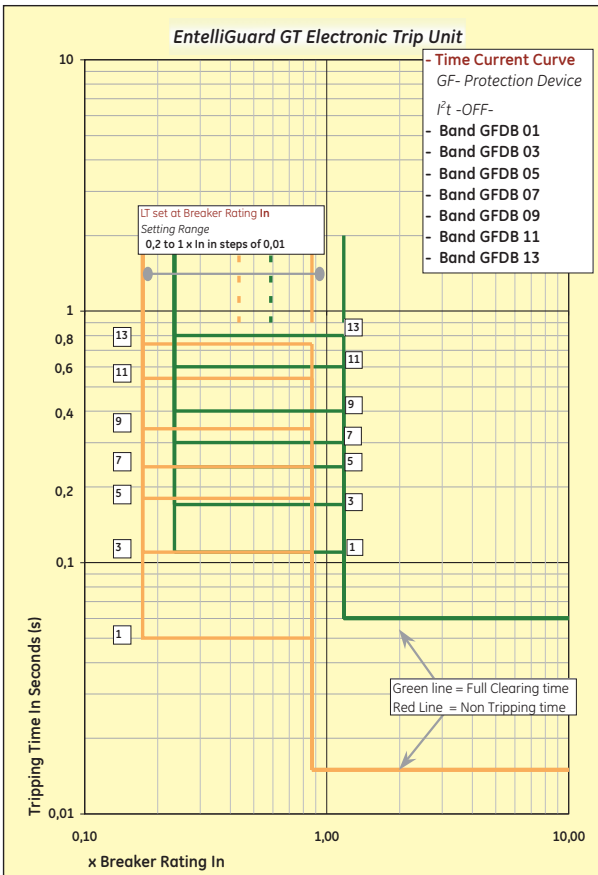
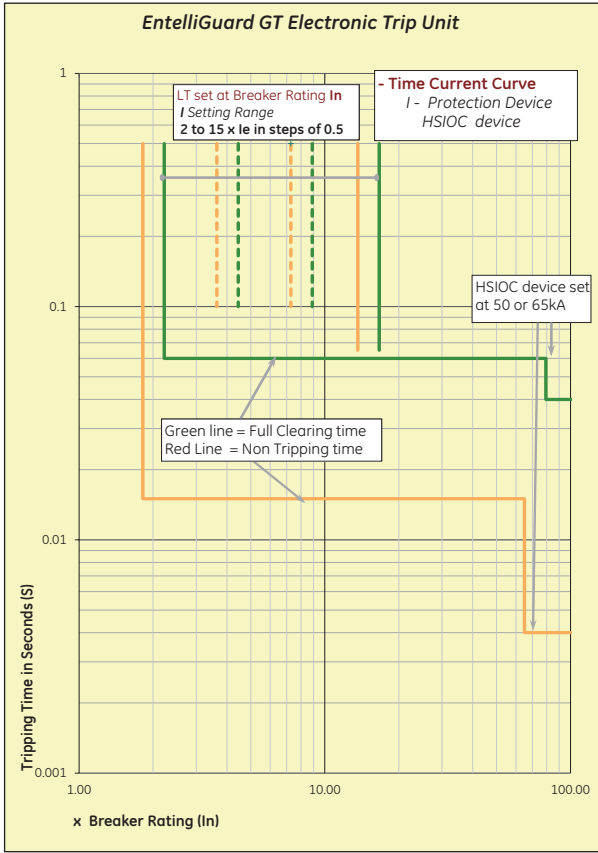

## Time Current Curves (cold state)

GF Protection Device

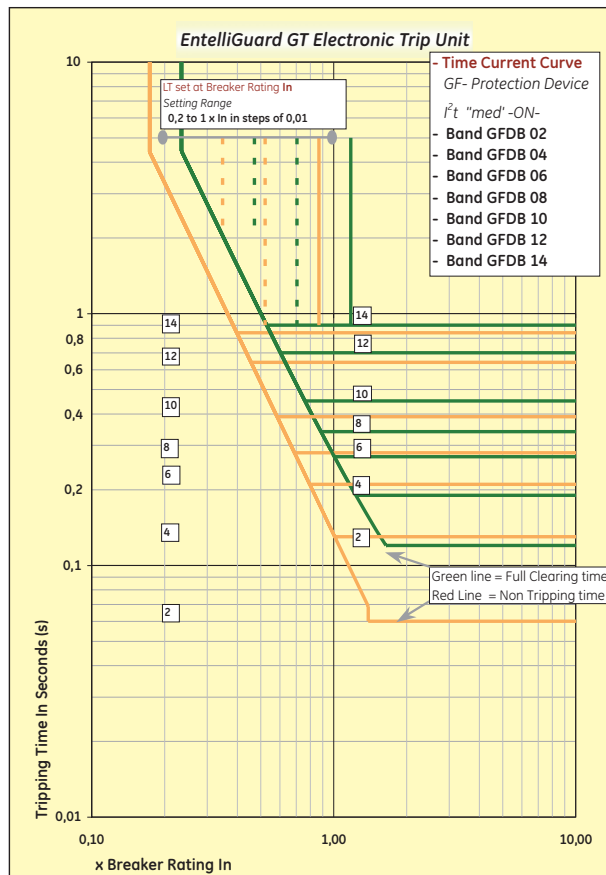
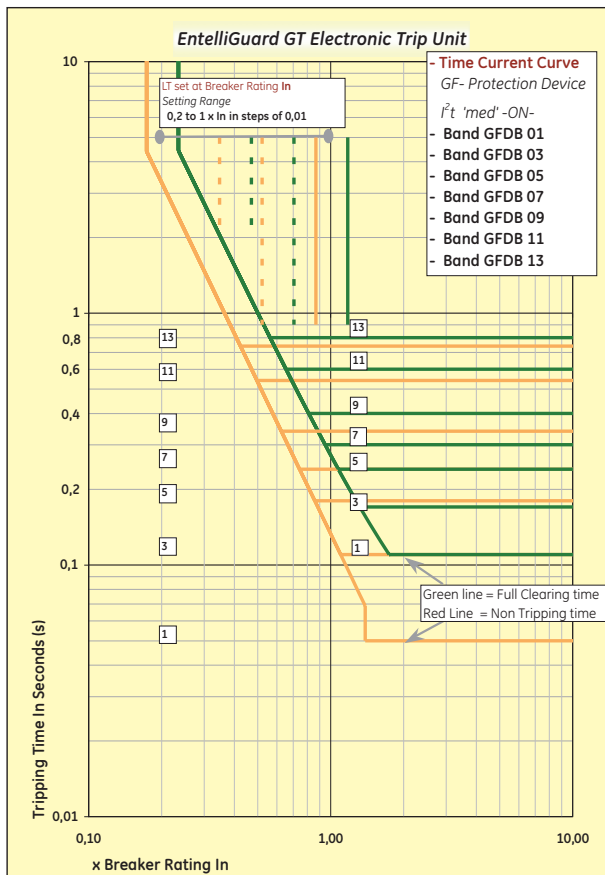
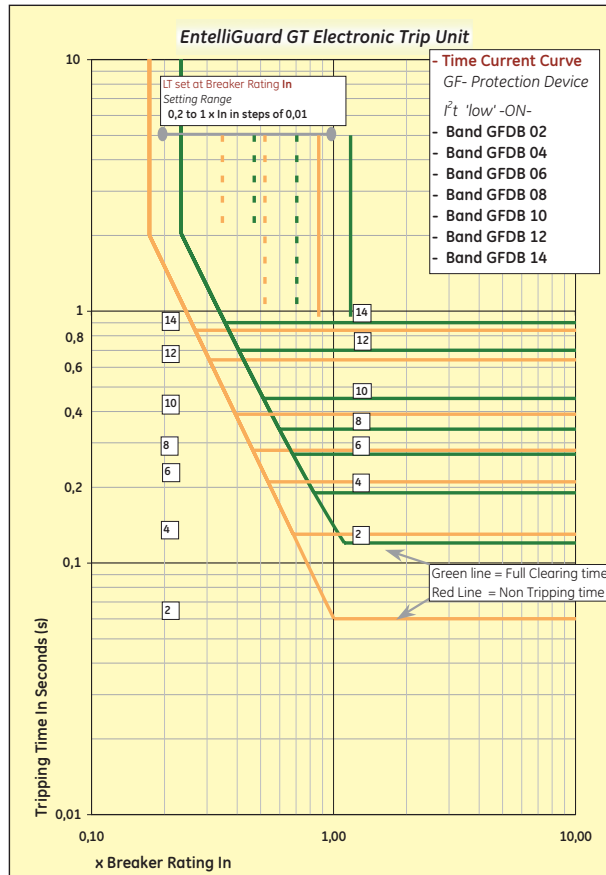
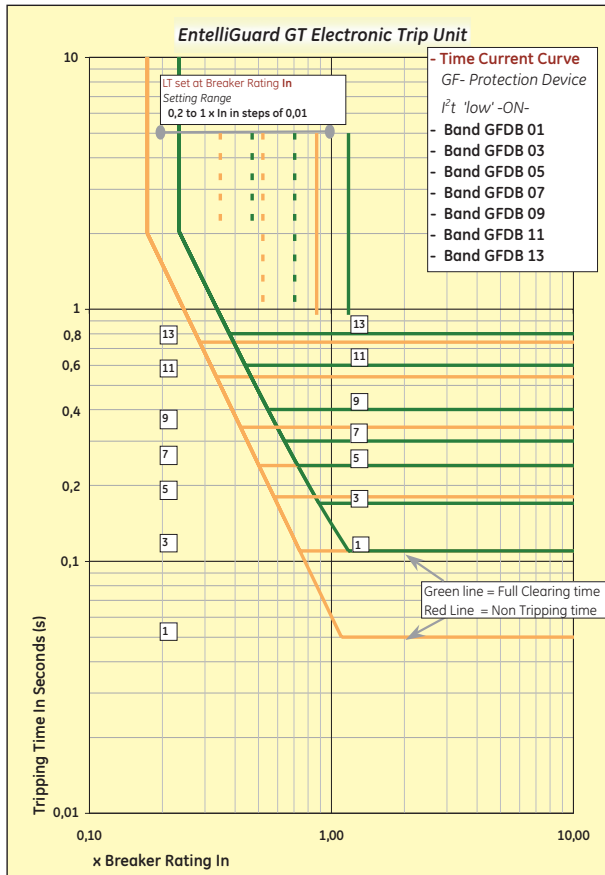

## Time Current Curves (cold state)

GF Protection Device

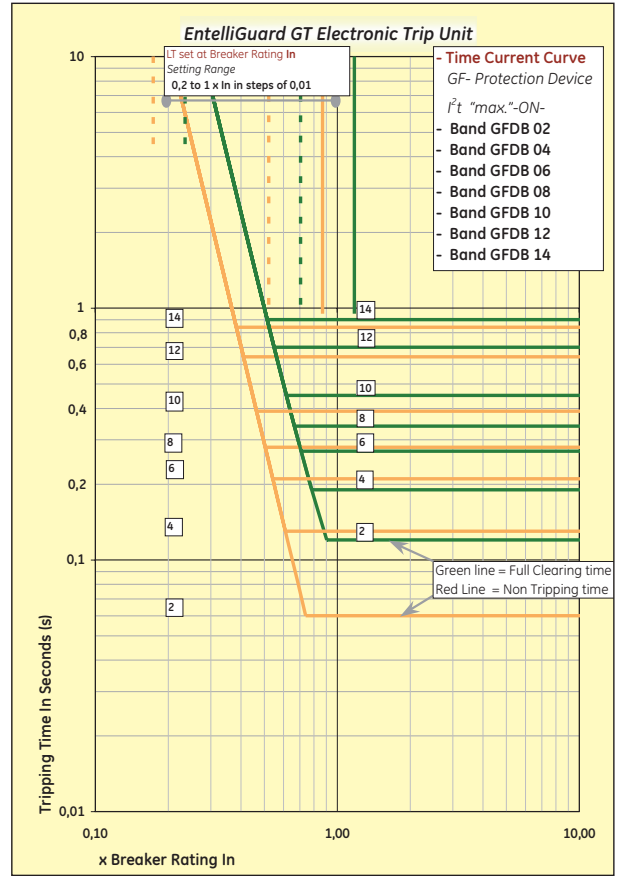
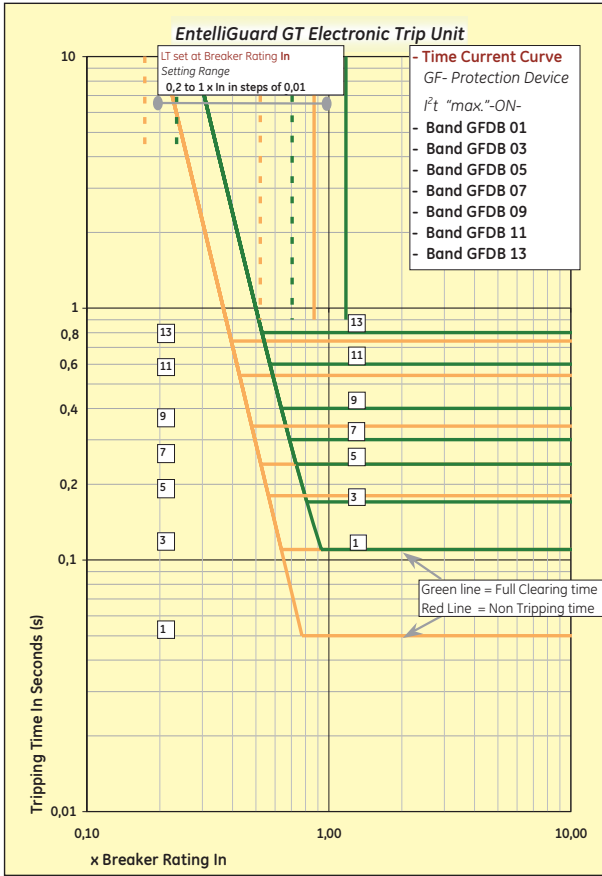

Denomination	Description
In	Current rating of Breaker
Ir	Current setting
LT	Long Time or Overload protection
ST	Short Time or Timed Short circuit protection
I	Instantaneous Short circuit protection (new IEC reference I <sub>i</sub> )
GF	Groundfault
Ir	LT or overload Current setting
Ist	ST or Timed Short circuit Current setting (new IEC reference I <sub>sp</sub> )
Ii	Instantaneous Short circuit Current setting
Ig	Ground, or Earthfault Current setting
LTDB	LT or overload time delay band (new IEC reference t <sub>t</sub> )
STDB	ST or short circuit time delay band (new IEC reference t <sub>sp</sub> )
I <sup>2</sup> t	'Slope' setting on ST or GF device
I <sup>2</sup> t	'Slope' setting on GF device
x LT	Multiple of LT or overload Current setting
x In	Multiple of Breaker Current rating
x CT	Multiple of installed sensor rating (In IEC EntelliGuard types =In)
I	Standard Instantaneous
MCR	Making Current Releas
HSIOC	Hi set Instantaneous protection.



## Time Current Curves (cold state)

Example of Full Time Current Curve

### Time Current Curve

The EntelliGuard™ Electronic trip unit has many sophisticated setting features and an extremely broad setting range. On request we can provide complete Time Current Curves covering all installed protection devices. The curves can be produced for any current setting within the range of the installed protection devices, for one or for a combination of two breakers. Please contact your local GE Sales Office for more information.

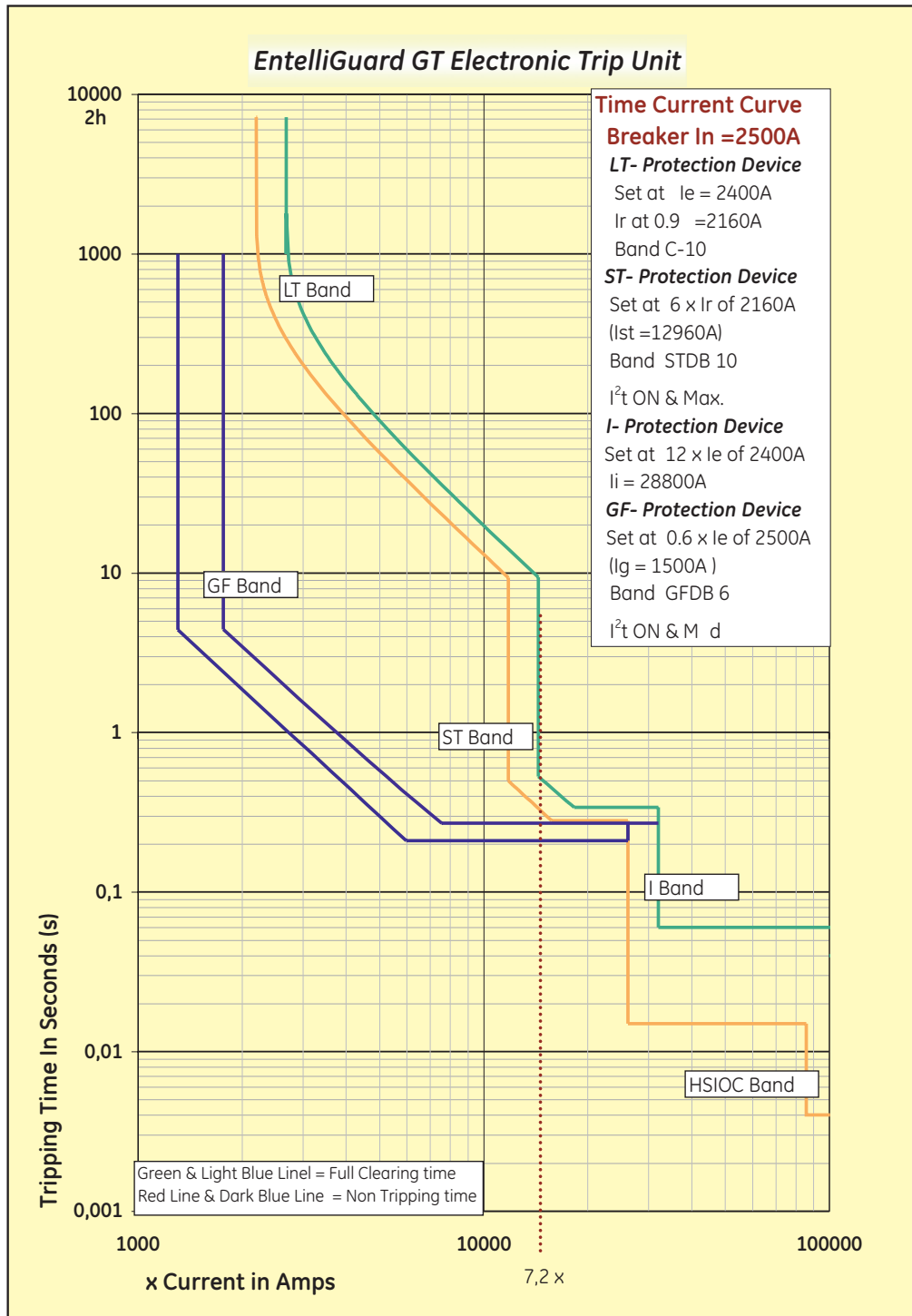

## Notes

Electronic Trip Units

Intro

A

**B**

C

D

E

X

A large grid of dotted lines for taking notes, covering the majority of the page.



**The Breaker & it's Accessories**

- C.2 Electrical Operation of Breaker (Motor Operator)
  - Electrical Operation of Breaker (Closing Coils)
  - Shunt & Undervoltage Releases
- C.3 Time Delay Module for Undervoltage Release
  - Auxiliary contact packages
  - Bell Alarm contact
- C.4 Spring charged and Ready to Close indication contacts
  - Operation counter
  - IP54 cover
  - Hoisting and Lifting facilities
  - Pushbutton padlock device
- C.5 Locking previsions on Breaker and Cassette
  - Door interlock
  - Carriage indication contacts
  - Spare parts for general use and maintenance purposes
- C.6 Mechanical Interlocking of multiple Breakers
- C.7 Breaker and Trip Unit schematics

Air Circuit Breakers

Order Codes

Electronic Trip Units

**Breaker Accessories**

Application Guide

Dimensions

Numerical index

Intro

A

B

**C**

D

E

X



## Breaker accessories

### Electrical charging mechanism (motor)

In order to charge the stored energy mechanism electrically, a motor mechanism is available. The design allows factory or field mounting and is available for the full range of EntelliGuard breakers. It is easily fitted with just three bolts.

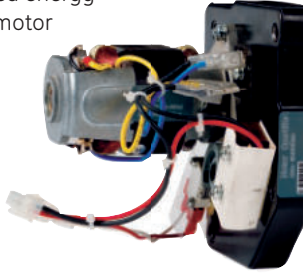

When the circuit breaker is opened, the mechanism automatically recharges the springs and prepares the breaker for an almost instantaneous reclosure should the need arise.

High speed recharging ensures that the springs are fully charged within four seconds. An optional 'ready to close' or 'spring charging indication' contact is available that indicates that the springs have been recharged and that the breaker can be closed.

The device is available in multiple AC and DC voltages and can be used in a operating frequency of up to two operations per minute. It has a life span equivalent to that of the breaker without maintenance. To switch the EntelliGuard breaker ON and OFF remotely a closing coil and shunt release is also necessary.

### Connections

The motor mechanism connection points can be found on terminal B of both the fixed pattern and draw-out breaker types. Please refer to page C.7.

### Electrical characteristics

Control voltage	Motor operator
24DC, 110-130DC, 220V DC	300W
110-130AC, 220 - 240AC	350VA

### Closing Coil

To switch the Air Circuit Breaker ON remotely a closing coil is available that when energized releases the spring charged closing mechanism. The device is available as a factory mounted component or as a field mountable device. It is an extremely easy-to-fit, clip-on unit, with simple plug-in connectors. The coils have a life span equivalent to that of the full breaker life span.



### Connections

The closing coils connection points can be found on terminal B of both the fixed pattern and draw-out breaker types. Please refer to page C.7.

### Electrical characteristics

AC	DC	Power consumption
--	24V	350 VA Inrush
--	48V	
110-130V	110-130V	
220-240V	220-240V	
380-415V	--	

### Shunt release

A device designed to switch the Air Circuit Breaker OFF remotely. When energized, a shunt release instantaneously activates the circuit breaker mechanism thus ensuring a rapid disconnection of the main contacts (50 msec). All EntelliGuard shunt release are suitable for a continuous power supply and are designed to be used as a closure prevention device when energized.



The device is available as a factory mounted component or as a field mountable device. It is an extremely easy-to-fit, clip-on unit, with simple plug-in connectors.

The individual devices have a wide voltage range, thus limiting the number of devices needed and have a life span equivalent to that of the full breaker life span.

### Undervoltage release

A device designed to open the breaker contacts and to prevent the breaker from closing when in a "No Volt" condition. On a de-energization the undervoltage release activates the circuit breaker mechanism and ensures a rapid disconnection of the main contacts (50 milliseconds). When not re-energized in accordance to the conditions stated in the IEC60947 the device prevents the Air Circuit Breaker from closing.



The EntelliGuard undervoltage releases are designed to react within a pre-defined voltage band, only reacting when the voltage supplying drops below the limits of this band. To prevent nuisance tripping due to short air interruptions or 'Brown Outs' the device has a built in delay of 50 milliseconds.



## Breaker accessories

The device is available as a factory mounted component or as a field mountable device. It is an extremely easy-to-fit, clip-on unit, with simple plug-in connectors.

The device have a wide voltage range, thus limiting the number of devices needed and can be used in an operating frequency of up to two operations per minute.

The release can have a life span equivalent to that of the full breakers life span.

### Connections

The connection points of both releases (UV and shunt) can be found on terminal B of both the fixed pattern and draw-out breaker types. Please refer to page 51.

### Electrical characteristics

AC	DC	Power consumption
--	24V	350 VA / 350 W Inrush 60 VA / 50W Holding
48V*	48V	
110-130V	110-130V	
220-240V	220-240V	
380-415V	--	

\* Applicable only to shunt release

### Time delay module

The de-energizing operation of the undervoltage release can be delayed. This optional, externally mounted module has an adjustable time delay of zero to three seconds. The device can be implemented to prevent undesired breaker tripping due to momentary voltage interruptions and is connected in series with the undervoltage release.



Optionally, the EntelliGuard trip unit can be supplied with a three phase plus neutral undervoltage protection device that can provide a power interruption alarm and/or initiate a breaker 'trip'.

### Electrical characteristics

AC	DC	Power consumption
110-130V	48 V	350 VA Inrush 60 VA Hold
220-240V	110 - 130V	
380-415V	220 - 240V	

### Auxiliary contacts

Auxiliary contacts are designed to indicate the position of the Air Circuit Breaker main contacts. Each EntelliGuard device is supplied with a standard package of 3 normally open (NO) and 3 normally closed (NC) contacts that operate simultaneously with the breakers main contacts. Optionally another package is available that can be used to increase the number of available contacts by replacing the standard auxiliary contact block.



### Auxiliary contact packages

Standard: 3 NO + 3 NC power rated  
Optional: 4 NO + 4 NC power rated

The devices are available as factory mounted components or as a field mountable device. Auxiliary contact packages are easy-to-fit, and have simple plug-in connectors.

Auxiliary switch characteristics	
<b>Power rated</b>	
<b>Nominal control voltage</b>	<b>Current rating</b>
AC 50 HZ	Non-inductive
110/120V	Amps
220/240V	10
380/415V	10
DC	5
110/120V	5
220/250V	0.25

### Connections

The connection points of the auxiliary contacts can be found on terminal C of both the fixed pattern and draw-out breaker types. When the standard 4 NO + 4 NC is required, only the standard terminal C is used. For other combinations terminal A needs to be ordered separately.

### Bell alarm contact

When an EntelliGuard Air Circuit Breaker has tripped due to a fault detected by the trip unit, a bell alarm changeover contact is available to indicate this. The contact can only be used when the breaker is adjusted to "Manual Reset".



### Connections

The connection points of the bell alarm contact can be found on terminal B of both the fixed pattern and draw-out breaker types.

## Breaker accessories

### Electrical characteristics

AC ratings		DC ratings	
Voltage	Amps	Voltage	Amps
250V	AC21-6A	125V 250V	DC21-0.4A DC21-0.2A

Minimum operating current 0.1A at 8V DC

### Spring charged and ready to close contacts

A breaker with electrical charging mechanism is equipped with a spring charged contact that closes if the spring mechanism is charged.



The second contact is ready to close indication, contact can optionally replace the spring charge contact. It only changes the indication when the following conditions are met:

- The circuit breaker is open
  - The closing springs are charged
  - The circuit breaker is not locked/interlocked in open position
  - There is no standing closing order
  - There is no standing opening order
- Both contacts are available in a 1 NO configuration.

### Electrical characteristics

AC ratings		DC ratings	
Voltage	Amps	Voltage	Amps
250V	AC21-6A	125V 250V	DC21-0.4A DC21-0.2A

Minimum operating current 0.16 A at 5V DC

### Operations counter

A simple and easy to install mechanical device that displays an accurate and cumulative record of the number of closing operations of the EntelliGuard Air Circuit Breaker in which it is installed.



The mechanical and electrical life span of the breaker can be extended by limited periodic maintenance. The counter contains information that can assist in determining when the breaker requires servicing.

### Terminal block

Breakers in fixed pattern, cassettes and breakers in draw-out mode are always supplied with an auxiliary connection block (terminal B and C).

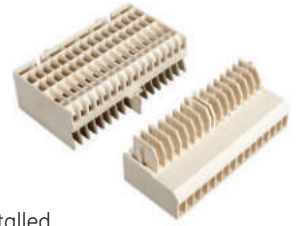

When the number of factory installed accessories exceed, the available number of connection points needed, a 3rd connection block is added (terminal A) accordingly. For connections please refer page 51.

### IP54 cover

All Air Circuit Breakers are supplied with a door flange/door frame that allows the user to finish the door cut-out professionally, simultaneously providing a protection degree of IP31.

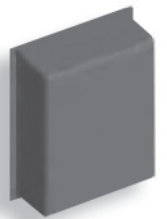

If a higher protection degree is required, an additional cover is available allowing IP54.

### Rogowski coils

If the EntelliGuard trip unit is configured to allow earth/ground fault protection, an external neutral sensor can be required. Rogowski coils for this application are available as separate items and are supplied with a mounting kit. Rogowski are also required for sensing the set values and then allowing the trip unit to provide protection accordingly.



### Hoisting / Lifting accessories

All EntelliGuard protection devices are equipped with a set of hoisting eyes. To use these hoisting eyes with standard lifting equipment, specifically designed adaptors are available.



### Fascia pushbutton padlocking facilities

To prevent unauthorized access to both the ON and OFF push buttons on the breakers front fascia, a padlockable push button cover can be fixed to the breaker front fascia. 1 padlock of 5-8 mm can be used.



## Breaker accessories

### Cassette key lock facilities

The Air Circuit Breaker can be equipped with optional cassette key locks. The key lock system encompasses a device fitted to the cassette allowing the lock functionality. The device ensures that a draw out circuit breaker cannot be moved from the TEST or DISCONNECT position unless the key has been inserted and secured within the lock. The locks also prevent the breaker from (all positions) being switched on.

### Breaker key lock facilities

The Air Circuit Breaker can be equipped with a key lock system. The key lock system encompasses a device fitted in the front fascia allowing the locks to be fitted and to separate locks. These devices ensure that a circuit breaker cannot be closed unless the key has been inserted and secured within the lock.

### Door interlock

A device designed to prevent the door of the equipment in which the breaker is installed to be opened when the Air Circuit Breaker is in connected position.

It is available in two executions; one for a door opening to the left and one to the right.

### Cassette position indication contacts

A breaker in draw-out mode has a cassette that is used for mounting and connecting. The breaker, in its moving position mode, can be inserted into the cassette and by use of the racking handle it can be moved to one of three positions; which are described below.

### Connected, test, disconnected or withdrawn

To indicate in which position the EntelliGuard breaker is located within the cassette, position indication contacts are available. The disconnected position is only being indicated when minimum isolating distances between contacts on both the main and auxiliary circuits have been achieved. Commonly referred to as carriage switches they are available as a factory mounted component or as a field mountable device.



### Spare parts for general use

The EntelliGuard™ Power Circuit breaker uses components that are designed to last the full life span of the device. However, certain components can be damaged or break during operational use. For these specific cases, the following spare parts are available:

- Racking handle (A)
- Breaker front cover (B)

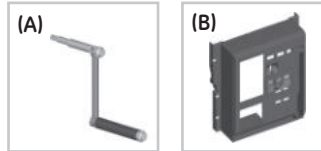

### Spare part for maintenance purposes

Air Circuit Breakers as the Entelliguard Power Circuit Breakers require periodic maintenance. Here, in some cases certain components critical to the devices functionality could need replacement.

Please contact our service department for specialist assistance in establishing which components need replacement and the physical replacement activities.

The following items are available:

- Arc Chutes (A)
- Fixed arcing Contacts (B)
- Cassette cluster contacts (C)
- Pliers to remove Cassette cluster contacts (D)

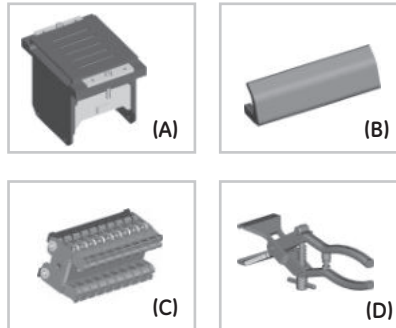

### Connections

The device is located in the left side base of the cassette substructure and can be accessed and connected directly.

### Electrical characteristics

AC ratings		DC ratings	
Voltage	Amps	Voltage	Amps
250V	AC21-10A	125V	DC21-0,5A
		250V	DC21-0,25A

\* Please contact our nearest authorised service centre for other available spare parts for EntelliGuard

## Mechanical Interlocking of Multiple Breakers

### Mechanically Interlocked Breakers

Many Low Voltage Installations have multiple power sources that are used in many different configurations. The power sources are required to supply the installation simultaneously, alternatively or in a certain logical combinations of both.

The EntelliGuard™ Power Circuit Breaker can be used to protect these Power supplies and be electrically and mechanically interlocked to provide the necessary logic. The mechanical interlocks are available for fixed and draw-out circuit breakers, enabling the direct interlocking of the breakers, mounted side by side or stacked.

The device has two parts; the first a kit customized for use with the breaker in fixed pattern or the cassette when a draw-out pattern is required (field mountable). Two or more specially designed field mountable cables available in lengths of 1,0; 1,6; 2,0; 2,5; 3,0; 3,5 and 4,0 meters being the second.



Any combination mode (fixed or draw-out), current rating, number of poles or envelope size can be interlocked. The interlocking systems are available in one configuration for 2 breakers and in three others for 3 breakers.

### Three Breaker Interlock type B

Interlock type B in which one of the three breakers (B1, B2 or B3) can be switched ON. Each breaker must be equipped with a factory mounted interlock type B. Six cables are needed.

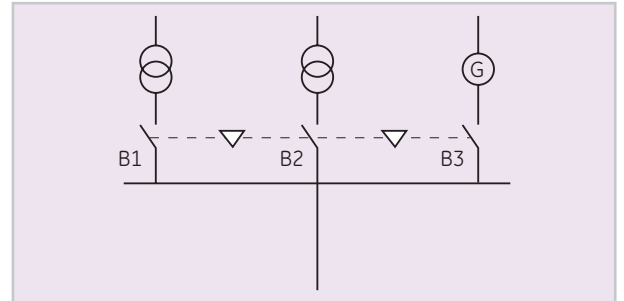

### Three Breaker Interlock type C

Interlock type C in which one or two of the three breakers can be switched ON in accordance with the inserted diagram. Each breaker must be equipped with a factory mounted interlock type C. Six cables are needed.

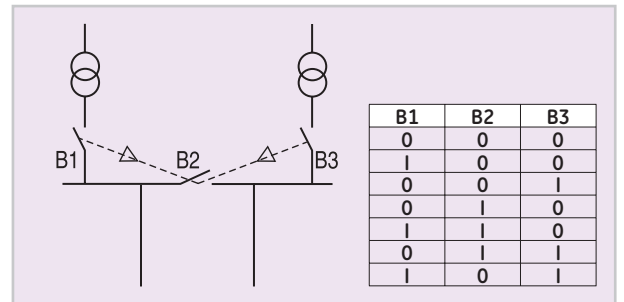

### Two Breaker Interlock

Interlock type A in which one of the two breakers (B1 or B2) can be switched ON. Each breaker must be equipped with a factory mounted interlock type A. Two cables are needed.

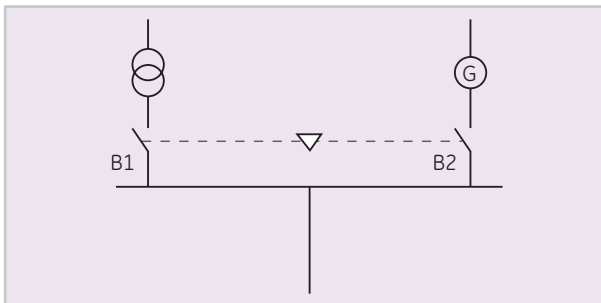

### Three Breaker Interlock type D

Interlock type D in which one or two of the three breakers can be switched ON in accordance with the inserted diagram. Breakers B1 & B3 must be equipped with a factory mounted interlock type A and B2 with a interlock type D. Four cables are needed.

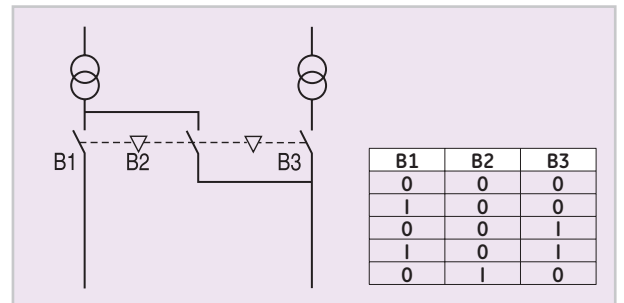

## Breaker connection scheme

Standard connection scheme for terminal Block B

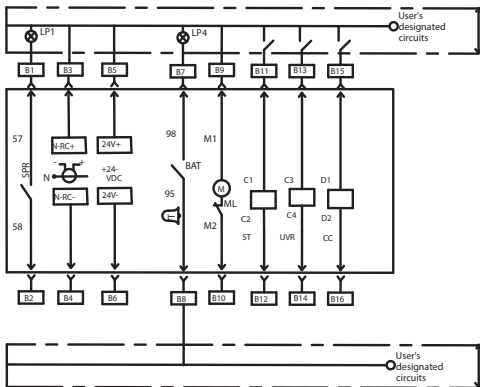

Optional connection scheme for terminal Block B

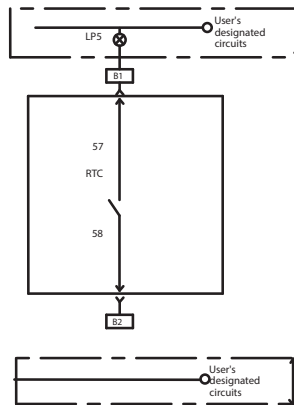

Standard connection scheme for terminal Block C

(When 3 sets of auxiliary contact are installed contacts 41 and 42 are not present)

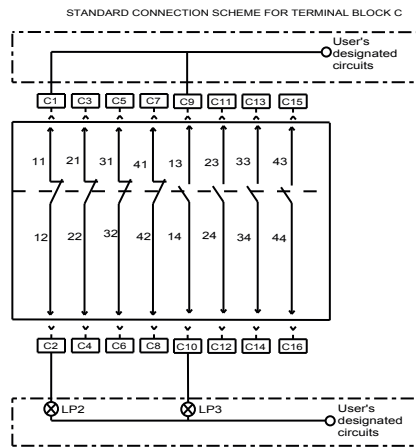

Connection scheme for terminal Block D

(Located on the side plate of the cassette. Depicted carriage switch scheme is of the two switch per position type)

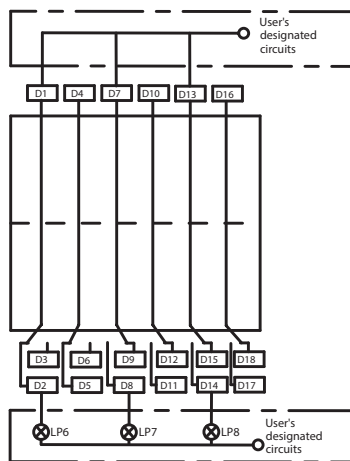

### Index

Trip unit		Indication (ct'd)		Abbreviations	
24V+/24V-	Auxiliary power supply to trip unit	LP5	Breaker ready to close	CC	Close coil
N-RC	Neutral rogowski coil	LP6	Disconnected position	ST	Shunt release
		LP7	Test position	UVR	Under voltage release
		LP8	Connected position	SFR	Spring change status
Indication				RTC	Ready to close status
LP1	Spring charge status			M	Motor operator
LP2	Breaker open			BAT	Bell alarm trip
LP3	Breaker closed				
LP4	Fault				

## Notes

Breaker Accessories

A large grid of dotted lines for taking notes, covering the majority of the page.

Intro

A

B

C

D

E

X



Air Circuit Breakers

Intro

Order Codes

A

Electronic Trip Units

B

Breaker Accessories

C

**Application Guide**

**D**

## Application Guide

- D.2 Handling, Mounting & Connecting
- D.3 Heat Dissipation, Watt loss & Current Ratings at temperatures >50°C
- D.4 Selectivity/Discrimination, general rules
- D.6 Protection of standard circuits
- D.7 Protection of Generator sets, Motor, Capacitor banks and Transformers
- D.7 Use of EntelliGuard Breakers in Automatic Power Transfer Systems (ATS)
- D.8 Environmental considerations

Dimensions

E

Numerical index

X



## Handling, mounting and connecting

### Clearance distances

A modern circuit breaker is designed to interrupt high short-circuit currents in a very limited time frame. In doing so the breaker vents gas and a limited amount of conductive fragments.

EntelliGuard Air Circuit Breakers have been designed to limit the venting phenomenon to a minimum, but certain clearances do need to be taken into account as indicated in the front and side views.

The maintenance of the fixed pattern devices requires access to the contacts and the removal of the arc chutes. A certain distance needs to be left above the breaker to allow for this as indicated in the front and side views.

Minimum clearance distances on fixed pattern breaker from housing to:		
	Metal parts	Insulated parts
A <sup>(1)</sup>	160	160
B1	30	30
B2	30	30

Minimum clearance distances from draw-out cassette housing to:		
	Metal parts	Insulated parts
A <sup>(2)</sup>	0	0
B1	30	30
B2	30	30

(1) Dimension allows for field arc chute replacements

(2) With cassette top covers; distance without these parts 160mm

### Handling

EntelliGuard Breakers in the fixed pattern and as draw-out portion have two retractable lifting eyes. One of these is located on the breaker right hand side and second on the left hand side (please see sketch).

The cassettes have four re-enforced tilting points with M10 screw thread.

### Recommended connection cross sections

The adjacent table indicates the recommended bus bar dimensions to be used in connecting the EntelliGuard Air Circuit Breaker.

#### Recommended copper busbar sizes (per phase)

Envelope	Rating (A)	Horizontal and flat/front termination	Vertical termination
1	630	2 x 50 x 5	1 x 100 x 5
	800	2 x 50 x 5	1 x 100 x 5
	1000	2 x 60 x 5	2 x 100 x 5
	1250	2 x 50 x 10	2 x 80 x 5
	1600	2 x 50 x 10	2 x 100 x 5
	2000	3 x 50 x 10	3 x 100 x 5
	2500	N/A	4 x 100 x 5
2	2000	3 x 50 x 10	3 x 100 x 5
	2500	4 x 50 x 10	4 x 100 x 5
	3200	4 x 100 x 10	4 x 100 x 10
	4000	(1)	4 x 100 x 10 + 1 x 100 x 5

(1) Consider vertical configuration. No horizontal configuration available.

### Front view fixed or draw-out pattern

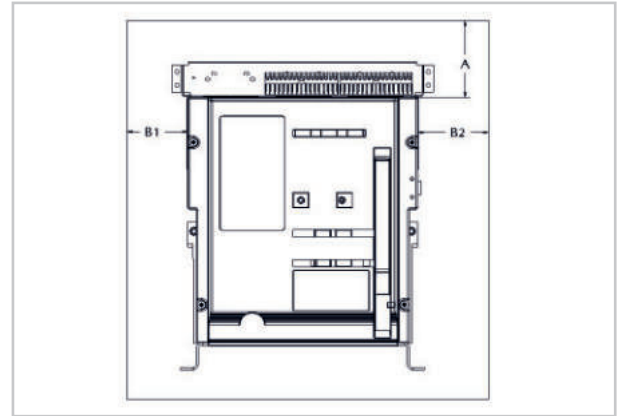

### Side view fixed pattern

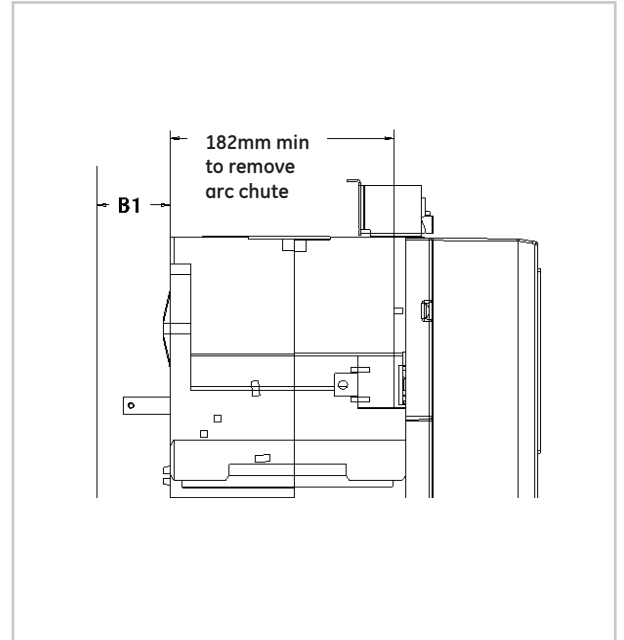

#### Recommended aluminium busbar sizes (per phase)

Envelope	Rating (A)	Horizontal termination	Vertical termination
1	400	2 x 40 x 8	2 x 40 x 8
	630	2 x 40 x 8	2 x 40 x 8
	800	2 x 50 x 8	2 x 50 x 8
	1000	2 x 50 x 10	2 x 50 x 10
	1250	2 x 63 x 12	2 x 63 x 12
	1600	4 x 50 x 8	4 x 50 x 8
	2000	(4)	3 x 100 x 10
	2500	(4)	4 x 100 x 10
2	2000	3 x 100 x 10	3 x 100 x 10
	2500	4 x 100 x 10	4 x 100 x 10
	3200	(4)	4 x 150 x 10
	4000	(4)	5 x 150 x 10

(3) With specifically designed Aluminium connection kit; please contact us.

(4) Consider vertical configuration. No horizontal configuration available.



## Heat dissipation, Watt loss and current ratings at temperatures >50°C

### Standards

The standard for low voltage equipment is defined in the EN 60439-1, the EN 50298 and the IEC 60890. These provide a theoretical method to calculate the temperature rise within an enclosure. The main element in these calculations is the power dissipation of the equipment installed. By totalizing this value for all the installed devices, connections, cables and busbars, it is possible to calculate the temperature rise within the enclosure. For normal applications a temperature rise within the enclosure of 50°C is assumed.

### Use

An enclosure manufacturer can provide the exact data on the allowable power dissipation within a certain enclosure. The values depend on the enclosure type, the ventilation it offers and where the components are located within this enclosure.

### EntelliGuard Air Circuit Breakers

The devices have been designed to offer the lowest, feasible heat dissipation value and the highest possible current ratings when enclosed. The tables here indicate the heat dissipation values and current ratings at temperatures within the direct vicinity of the breaker in free air.

The values apply for breakers used with rear connections and the preferred vertical busbars. The recommended connection cross sections can be found on page D.2

EntelliGuard L type	Envelope	In in A	Power loss at In per pole in Watts		Temperature in the direct environment of the EntelliGuard											
					≤50°C	55°C	60°C	65°C	70°C	≤50°C	55°C	60°C	65°C	70°C		
					Maximum user Current Ie in A Vertical connection mode: Fixed pattern					Maximum user Current Ie in A Vertical connection mode: Draw out pattern						
			Fixed breaker	Drawout breaker												
LG04S	1	400	4,60	8,80	400	400	400	400	400	400	400	400	400	400	400	400
LG04N - LG04R	1	400	2,40	4,80	400	400	400	400	400	400	400	400	400	400	400	400
LG07S	1	630	11,80	21,80	630	630	630	630	630	630	630	630	630	630	630	630
LG07N - LG07R	1	630	6,00	11,90	630	630	630	630	630	630	630	630	630	630	630	630
LG08S	1	800	19,20	35,20	800	800	800	800	800	800	800	800	800	800	800	800
LG08N - LG08R	1	800	9,60	19,20	800	800	800	800	800	800	800	800	800	800	800	800
LG10S	1	1000	30,00	55,00	1000	1000	1000	1000	1000	1000	1000	1000	1000	1000	1000	1000
LG10N - LG10R	1	1000	15,00	30,00	1000	1000	1000	1000	1000	1000	1000	1000	1000	1000	1000	1000
LG13S	1	1250	46,90	85,90	1250	1250	1250	1250	1250	1250	1250	1250	1250	1250	1250	1250
LG13N - LG13R	1	1250	23,40	46,90	1250	1250	1250	1250	1250	1250	1250	1250	1250	1250	1250	1250
LG16S	1	1600	66,60	128,00	1600	1600	1600	1600	1600	1600	1600	1500	1400	1350		
LG16N - LG16R	1	1600	38,40	76,80	1600	1600	1600	1600	1600	1600	1600	1600	1600	1600	1600	1600
LG20S & N - LJ20R	1	2000	60,00	120,00	2000	2000	2000	2000	2000	2000	2000	2000	2000	2000	2000	2000
LG25S & N - LJ25R	1	2500	93,80	187,00	2500	2500	2500	2500	2500	2500	2450	2232	2100	2000		
LG20, C & D - LJ20C	2	2000	60,00	120,00	2000	2000	2000	2000	2000	2000	2000	2000	2000	2000	2000	2000
LG25, C & D - LJ25C	2	2500	93,80	187,00	2500	2500	2500	2500	2500	2500	2500	2500	2500	2500	2500	2500
LG32, C & D - LJ32C	2	3200	81,90	184,30	3200	3200	3100	3050	3000	3200	3200	3100	3050	3000		
LG40, C & D - LJ40C	2	4000	128,00	256,00	4000	3750	3500	3350	3200	4000	3750	3500	3350	3200		

EntelliGuard L type	Envelope	In in A	Power loss at In per pole in Watts		Temperature in the direct environment of the EntelliGuard											
					≤50°C	55°C	60°C	65°C	70°C	≤50°C	55°C	60°C	65°C	70°C		
					Maximum user Current Ie in A Horizontal connection mode: Fixed pattern					Maximum user Current Ie in A Horizontal connection mode: Draw out pattern						
			Fixed breaker	Drawout breaker												
LG04S	1	400	4,60	8,80	400	400	400	400	400	400	400	400	400	400	400	400
LG04N - LG04R	1	400	2,40	4,80	400	400	400	400	400	400	400	400	400	400	400	400
LG07S	1	630	11,80	21,80	630	630	630	630	630	630	630	630	630	630	630	630
LG07N - LG07R	1	630	6,00	11,90	630	630	630	630	630	630	630	630	630	630	630	630
LG08S	1	800	19,20	35,20	800	800	800	800	800	800	800	800	800	800	800	800
LG08N - LG08R	1	800	9,60	19,20	800	800	800	800	800	800	800	800	800	800	800	800
LG10S	1	1000	30,00	55,00	1000	1000	1000	1000	1000	1000	1000	1000	1000	1000	1000	1000
LG10N - LG10R	1	1000	15,00	30,00	1000	1000	1000	1000	1000	1000	1000	1000	1000	1000	1000	1000
LG13S	1	1250	46,90	85,90	1250	1250	1250	1250	1250	1250	1250	1250	1250	1250	1250	1250
LG13N - LG13R	1	1250	23,40	46,90	1250	1250	1250	1250	1250	1250	1250	1250	1250	1250	1250	1250
LG16S	1	1600	66,60	128,00	1600	1500	1450	1400	1350	1600	1500	1450	1400	1350		
LG16N - LG16R	1	1600	38,40	76,80	1600	1600	1600	1600	1600	1600	1600	1600	1600	1600	1600	1600
LG20S & N - LJ20R	1	2000	60,00	120,00	2000	2000	2000	2000	2000	2000	2000	2000	1900	1800		
LG25S & N - LJ25R	1	2500	93,80	187,00	2500	2450	2232	2100	2000							
LG20, C & D - LJ20C	2	2000	60,00	120,00	2000	2000	2000	2000	2000	2000	2000	2000	2000	2000	2000	2000
LG25, C & D - LJ25C	2	2500	93,80	187,00	2500	2500	2500	2500	2500	2500	2500	2500	2500	2500	2500	2500
LG32, C & D - LJ32C	2	3200	81,90	184,30	3200	3200	3100	3050	3000	3200	2800	2700	2650	2500		



## Selectivity/Discrimination

### Selectivity/Discrimination

In a low voltage distribution network it is necessary that during a fault, the protection device nearest to the fault reacts whilst all others remain closed.

This capability is called discrimination or selectivity.

If this requirement is not met a fault in one arm of the distribution system could cause a number of upstream protection devices to react and open. A relatively minor fault in one arm of a complete distribution will then cause a power interruption across a major part of the installation.

### EntelliGuard Air Circuit Breakers

A combination of the high precision and multiple bands of the EntelliGuard Electronic Trip Unit allow full selectivity to be achieved between closely rated devices over multiple levels.

The table included here indicates the recommended settings of the upstream EntelliGuard Breaker as a ratio to that of the downstream protection devices.

A second table on page 45 indicates the discrimination/selectivity that can be achieved with these settings. The tables can replace the complex and time consuming method of comparing multiple time current curves across many levels.

Downstream device	Trip Unit	Setting denomination	Settings determining delectivity	Recommended EntelliGuard settings				
				I <sub>r</sub> or I <sub>e</sub> setting ratio	LTDB setting band	I <sub>st</sub> setting ratio	STDB setting band	I setting
<i>Record Plus</i>								
FD and FE frame	LTMD	I <sub>r</sub>	Ratio and Band	1.6 x	C22			
		I <sub>m</sub>	Ratio and Band			1.6 x	Band 2	
FD and FE frame	GTM	I <sub>r</sub>	Ratio and Band	1.6 x	C22			
		I <sub>m</sub>	Ratio and Band			1.6 x	Band 2	
FE frame PremEon S	SMR PremEon S	LTD Motor	Band	1.3 x	C14			
		I <sub>st</sub>	Ratio and Band			1.35 x	Band 2	
FG frame PremEon S	SMR1	LTD Motor	Band	1.3 x	C14			
		I <sub>st</sub>	Ratio and Band			1.35 x	Band 3	
		I <sub>r</sub>	Ratio	1.3 x				
		LTD cl.1.25	Band		C3			
		LTD cl. 2.5	Band		C5			
		LTD cl. 5	Band		C8			
		LTD cl.10	Band		C12			
		LTD cl.20	Band		C16			
		LTD cl.30	Band		C18			
		I <sub>st</sub>	Ratio			1.35 x		
		STD=420ms	Band				Band 13	
		STD=310ms	Band				Band 11	
		STD=210ms	Band				Band 9	
		STD=120ms	Band				Band 6	
		STD=40ms	Band				Band 3	
FK frame	SMR1e	I <sub>r</sub>	Ratio and Band	1.4 x	C8			
		I <sub>st</sub>	Ratio			1.35 x		
		STD	Band				Band 7	
		I <sub>r</sub>	Ratio	1.4 x				
		LTD cl. 5	Band		C8			
		LTD cl.10	Band		C12			
		LTD cl.20	Band		C19			
		LTD cl.30	Band		C22			
		I <sub>st</sub>	Ratio					
		STD=300ms	Band				Band 12	
		STD=200ms	Band				Band 10	
		STD=100ms	Band				Band 7	
		I <sub>r</sub>	Ratio	1.25 x				
		LTD class	Band		2 higher			
		I <sub>st</sub>	Ratio			1.25 x		
		STD band min, until 11	Band				2 higher	
		STD band ≤12					1 higher	
EntelliGuard	GT-L, -E, -S '-N, -H, -HE							Use ZSI or I = 'OFF'
Industrial fuses GL/Gg type	----	Current rating	Ratio and Band	2 x	F20	ST = 8 x I <sub>r</sub> , STDB band 5 and I = 12 x I <sub>e</sub>		



## Selectivity / Discrimination table

Downstream Device	Trip Unit	Upstream EntelliGuard device and Selectivity limit I <sub>2</sub> <sup>(1)</sup>				
		GG04S to GG20S	GG04N to GG20N	LG04N to LG25N	LG20C to LG40C	GG25N to GG40N
<b>Elfa Plus MCB's</b>						
EP30,45, 60,100&250, CP30,45&60, DME60, DPE100, DP(A)60, DP(A)100 & DPT100	All	T		T	T	T
<b>Elfa Plus MCB's</b> HTI & S90 C curve	All	T		T	T	T
<b>Surion Manul Motor starters</b> GPS1BS <=10A GPS1MH<=12.5A GPS2BS 10A, GPS2MH 10A	All	T		T	T	T
<b>Surion Manul Motor starters</b> GPS1BS, GPS1MS 12.5kA, GPS1MH > 12.5A, GPS2MH >10A	All	T		T	T	T
<b>Surion Manul Motor starters</b> GPS1BS, GPS1MS >=16A, GPS2BS >10A	All	T		T	T	T
<b>Record Plus</b>						
FD& FE frame C, E, V, S tiers	All	T		T	T	T
FD& FE frame N tier	All	T		T	T	T
FD& FE frame H tier	All	T		T	T	T
FD& FE frame L tier	All	T		T	T	T
FG frame N tier	All	T		T	T	T
FG frame H tier	All	T		T	T	T
FG frame L tier	All	T		T	T	T
FK frame N tier	All	T		T	T	T
FK frame H tier	All	T		T	T	T
FK frame L tier	All	T		T	T	T
<b>EntelliGuard L</b>						
LG04S to LG25S	All	50kA		T	50kA	T
LG04N to LG25N	All	50kA		65kA	50kA	65kA
LG20C to LG40C	All	50kA		T	50kA	T
LG20D to LG40D	All	50kA		65kA	50kA	65kA
<b>Industrial fuses</b> GL/Gg type	-	T		T	T	T

(1) T = Full discrimination until the I<sub>cu</sub> of the downstream or upstream device. (the lowest of the two)

Selectivity is also present with upstream EntelliGuard G devices type GG04E to GG40E, GG(GH)25H to GG(GH)40H, GG(GH)25M to GG(GH)40M, GG32G to GG40G, GG40M to GG64M and GG40L to GG64L.

## Protection of standard circuits

### Protection of standard circuits

Protection devices as the EntelliGuard Air Circuit breaker are used in a wide variety of environments to protect conductors, equipment and devices in low voltage distribution circuits. To use this product to its full potential, it is necessary to verify that it functions correctly in the environment in which it is used, and that it meets the electrotechnical requirements of the circuit it protects.

### Environment

EntelliGuard will function well in almost any industrial environment and fully complies with the environmental requirements of the relevant EN60947-2 standard.

### Maximum short-circuit current

Each protective device must be capable of interrupting the maximum short-circuit current at the point where it is installed (see HD384 standard). The interruption ratings (Breaking Capacities) of the EntelliGuard circuit breaker can be found on page 3 of this catalogue.

### Design current of a circuit

The equipment and devices in an electrical circuit determine its current load or design current (I<sub>b</sub>). A circuit breaker's overload or I<sub>r</sub> setting is normally adjusted to a value equal to the design current.

### Weakest short-circuit current in a circuit

On a short-circuit event, the total circuit impedance determines both the MAXIMUM and WEAKEST short-circuit current that can flow in the circuit.

For the weakest short circuit current, it is necessary to establish if the protection device trips before the electrical conductors reach their maximum temperature, this for operating times of 0.1 to 5 seconds.

### Fault currents

In the 2005 edition of the IEC60364-4-41 the general terminology, 'Protection against Electrical shock' has been adapted whilst two new terms have been introduced:

- 1) Protection under normal conditions now designated:

#### Basic protection

- 2) Protection under fault conditions now designated:

#### Fault protection

Fault protection being provided by protective equipotential bonding and automatic disconnection of the supply. Under fault conditions, depending on the network an interruption time of 5 seconds (TN) or 1 second is required (TT) for circuits with a rating >32A. Depending on the configuration of the earthing system, the 1 and 5 second disconnection time is also required for interruption of a second fault in IT systems.

### EntelliGuard Air Circuit breakers

To protect standard circuits, the breakers are equipped with a number of protection devices.

#### Overload protection device

First highly accurate menu driven overload protection device that has an adjustment range of 0.4 to 1 x the breaker rating, in thirteen steps.

This device is normally set to a value that is equal or closely matches the design current (I<sub>b</sub>).

#### Timed short-circuit protection device

Set as a multiple of the overload adjustment. This device offers a broad adjustment range of 1.5 to 12.

The setting of this device depends on several parameters:

- inrush characteristics of the protected devices
- protection against the **weakest short-circuit current**
- fault currents to earth

17 narrow and accurate time bands allow the EntelliGuard Air Circuit Breaker to interrupt a fault within the timing required by the standards, to offer selectivity across multiple levels and allow the user to take inrush currents into account.

#### Ground fault protection

It is possible to combine two devices to detect **fault currents** to earth. They can be set as a multiple of the value of the current sensors mounted in the breaker and have a broad adjustment range of 0.2 to 1 times the breaker rating.

The first is a residual device that takes the sum of the current in three phases and neutral. If this is no longer equal to zero it sends an alarm or trips the breaker.

The second allows the user to measure the return current running between the earth leg and neutral. On detecting a fault to earth, the device sends an alarm, or trips the breaker.

14 narrow and accurate time bands allow the EntelliGuard Air Circuit Breaker to interrupt a fault within the timing required by the standards and offer selectivity across multiple levels.

#### Instantaneous short-circuit protection

Set as a multiple of the primary overload adjustment I<sub>e</sub> this device offers a broad adjustment range of 2 to 15.

This device is normally used to limit the time that higher short-circuit currents can run in the protected circuit. Whilst the timed short-circuit protection device waits for a set time, the instantaneous device immediately trips the breaker once the set value is reached.

The device used in the EntelliGuard Air Circuit Breaker maintains selectivity by only reacting to the 2nd half wave of a short-circuit current and uniquely allows the use of the 'Zone Selective Interlock' feature.

## Applications

### Protection of generator sets, motors, capacitor banks and transformers

#### Use of EntelliGuard Breakers in Automatic Power Transfer Systems (ATS)

#### Introduction

The electronic trip unit used in the EntelliGuard Air Circuit Breaker offers many additional protection devices. Here number of the possible applications of these devices are described briefly.

#### Protection of generator sets

The overload and short-circuit devices used to protect a generator need to react quicker and at lower current levels than those used to protect other devices.

After establishing, the capabilities of the generator are set under overload and short-circuit conditions. The protection devices need to be adjusted accordingly.

On a Air Circuit Breaker use of the 'faster' overload protection bands (LTDB set between minimum and the C6 band) and a low setting of the timed short-circuit protection ( $2.5 \times I_r$ ) is recommended. The optional 3 phase undervoltage protection available in the GT-H trip unit can also be considered.

#### Protection of motors

On starting, electrical motors draw more current than when running under normal conditions. These starting currents differ strongly per type and should not cause tripping of the device protecting the circuit.

The IEC60947-4 has defined four different 'Operational' or 'Trip' classes:

Trip class	Required tripping times at		
	$1.2 \times I_n$	$1.5 \times I_n$	$7.2 \times I_n$
10A	$t < 2$ hours	$t < 2$ min.	$2 \leq t \leq 10$ sec.
10	$t < 2$ hours	$t < 4$ min.	$4 \leq t \leq 10$ sec.
20	$t < 2$ hours	$t < 8$ min.	$6 \leq t \leq 20$ sec.
30	$t < 2$ hours	$t < 12$ min.	$9 \leq t \leq 30$ sec.

This table is in some cases extended to include a 'Trip class 40' (assumed to be a 15-40 second band at  $7.2 \times I_n$ ).

On a Air Circuit Breaker, use of the 'slower' protection bands that closely match the indicated classes is recommended (LTDB set between the C8 to the C22 band).

Switching on a motor also produces a high but very short inrush peak current which could activate the short-circuit protection of a breaker and cause unexpected tripping. Here the timed short-circuit device of a Air Circuit Breaker must be set to at least  $12 \times I_r$  with a time delay of 50 milliseconds (STDB band 3). If an instantaneous protection device is present and switched on, a setting of at least  $12 \times I_e$  is recommended.

After an overload event, if motor and wiring are still warm, a immediate re-energization of the electrical circuit could result in damage of the electrical circuit and the motor.

The overload protection device must incorporate a thermal memory device that prevents re-energization before a certain cooling time has elapsed.

#### Remark

Furthermore, the prevention of anomalies as the motor losing a phase or a motor with blocked rotor need to be prevented and require additional protection devices.

Next to the 'Standard' protection devices, the EntelliGuard Electronic Trip Unit has a thermal memory function, an optional 3 phase undervoltage relay and current unbalance device, thus providing comprehensive motor protection.

#### Protection of capacitor banks

Air Circuit Breakers are designed to offer high making and breaking capacities under adverse conditions: The switching of capacitor banks has little to no effect on the breaker, its characteristics as a protective device or on its lifespan.

However the current flowing in the circuit can trip a circuit breaker and a capacitor load does display certain anomalies. Here the current flowing in the circuit cannot be assumed to be the calculated capacitor current only. The effective current value is higher due to harmonic content (normally assumed as 30%) and an allowance must be made for tolerances in the capacitance of the units (10%). The protection devices of the Air Circuit Breaker must be set accordingly.

#### Protection of LV / HV transformers

Transformers generally produce a very high inrush current. The crest values of the first half cycle may reach values of 15 to 25 times the normal rated current. Manufacturers data and tests have indicated that, a protection device feeding a transformer must be capable of carrying the following current values without tripping.

Transformer value	Crest inrush values		
	1st period	2nd period	After 3 periods
$< 50$ kVA	$25 \times I_n$	$12 \times I_n$	$5 \times I_n$
$\geq 50$ kVA	$15 \times I_n$	$8 \times I_n$	$3.5 \times I_n$

It is recommended that the timed short-circuit device of a Air Circuit Breaker is set to at least  $8 \times I_r$  with a time delay of 30 milliseconds (STDB band 1). If an instantaneous protection device is present, the use of the extended adjustment range with setting of  $20 \times I_e$  is advisable ( $=15 \times I_n$  plus tolerances).

#### Automatic Transfer Systems (ATS)

EntelliGuard Air Circuit Breakers are available with mechanical interlocks for 2 to 3 breakers and have a unique electrical network interlocking system allowing the user to completely lock out one or more breakers.

The logical transfer of power from one source to another is thus strongly simplified whilst the high speed electrical closing and opening of the device allows their use in synchronization applications.

Here, numerous other EntelliGuard protection features can be used, one of which being the Electronic Trip unit 3 phase undervoltage release. This is to establish if voltage on a certain power source is present and if a generator set has reached its nominal voltage.



## Environmental considerations

### Ambient temperature

EntelliGuard Air Circuit Breakers are designed to operate normally at temperatures of -5 degrees to +70°C. They can be used at temperatures down to -20°C with a reduced electrical and mechanical life span.

To prevent materials from reaching temperatures that have an adverse effect on their electrical and/or mechanical properties, de-rating factors must be applied when the device is used in ambient temperatures higher than 50°C.

### Storage temperature

Air Circuit Breakers can be stored at non operational temperatures of -40° degrees up to +70°C.

### Influence of altitude

Up to an altitude of 2000m above sea level no de-rating of breaker rated current or rated voltage is applicable. For altitudes above 2000m the following de-rating factors apply:

Altitude	Altitude correction factors		
	≤ 2000M	2500M	4000M
Voltage (Ue)	1	0.95	0.80
Current (In)	1	0.99	0.96

### Other atmospheric conditions

The EntelliGuard breaker line has been designed to operate at the temperatures and relative humidities defined in the EN 60947 clause 6.1.3.1.

They also meet the requirements of the following standards:

IEC 68-2-1	Cold
IEC 68-2-2	Dry heat
IEC 68-2-3	Damp heat
IEC 68-2-11	Salt
IEC 68-2-14	Change of temperature
IEC 68-2-30	Damp heat cyclic
IEC 721	Climatic

### Vibration

Air Circuit Breakers meet the vibration requirements of the following standards:

IEC 68-2-6	Vibration
------------	-----------

### Other

All EntelliGuard devices meet the existing European ROHS directive.

### Electromagnetic compatibility

The EntelliGuard Air Circuit Breaker and its electronic trip unit meet the most stringent requirements of the EN 60947-2 and IEC 1004 standard. The following tests have been successfully completed.

### Harmonics, current dips, interruptions and power frequency variations

All EN 60947 annex F, sub-clause F4.1 through 3 requirements covering non sinusoidal currents resulting from harmonics are met. Testing covering the following elements:

- wave forms consisting of a fundamental + 3rd harmonic component at 50 and 60Hz
- wave forms consisting of a fundamental + 5th harmonic component at 50 and 60Hz
- composite wave forms with a fundamental component + a 3rd, 5th and 7th harmonic at 50 and 60Hz
- current dips and current interruptions
- frequency variations from 45 to 65Hz in 1 Hz steps

### Electrostatic discharge

EN 60947 annex F, sub-clause F and the IEC 1004-2

- passed level 4, air discharge 15kV

### Radiated, radio frequency, electromagnetic field immunity test

EN 60947-2 annex F, sub-clause F7 and the IEC 1000-4-3 (basic standard)

- passed higher than level 4 field strength 30V/m

### Electrical fast transient / Burst

EN 60947-2 annex F, sub-clause F5 and the IEC 1000-4-4 (basic standard)

- passed level 4 burst peak voltage 4kV

### Surge immunity test

EN 60947-2 annex F, sub-clause F5 and the IEC 1000-4-5 (basic standard)

- passed level 4 voltage 1.2µs/50µs 6kV; current 8µs/20µs 3kA

### Dry heat test

EN 60947-2 annex F, sub-clause F8

- passed all test requirements

### Thermal shock test

EN 60947-2 annex F, sub-clause F9

- no nuisance tripping within the 28-day temperature cycles

## Notes

Grid area for notes.

## Notes

A large grid of dotted lines for taking notes, spanning the majority of the page.





### Dimensional Drawings

- E.2 Envelope 1 Fixed type
- E.3 Envelope 1 Draw out type, Universal connection pads
- E.4 Envelope 1 Draw out type, Horizontal connections
- E.5 Envelope 2 Fixed type
- E.6 Envelope 2 Draw out type, Universal connection pads
- E.7 Envelope 2 Draw out type, Horizontal connections
- E.8 Envelope 2 Draw out type 4000A, Vertical connection pads
- E.9 Alternate connection modes
- E.10 Ip54 Flange, Time Delay Module UVR, 24V power supply
- E.11 Rogowski sensors, Door interlock system
- E.12 Interlocking with cable systems; 2 way
- E.13 Interlocking with cable systems; 3 way

Air Circuit Breakers

Order Codes

Electronic Trip Units

Breaker Accessories

Application Guide

**Dimensions**

Numerical index

Intro

A

B

C

D

**E**

X



## Envelope 1 - Fixed Pattern

Dimensional drawings

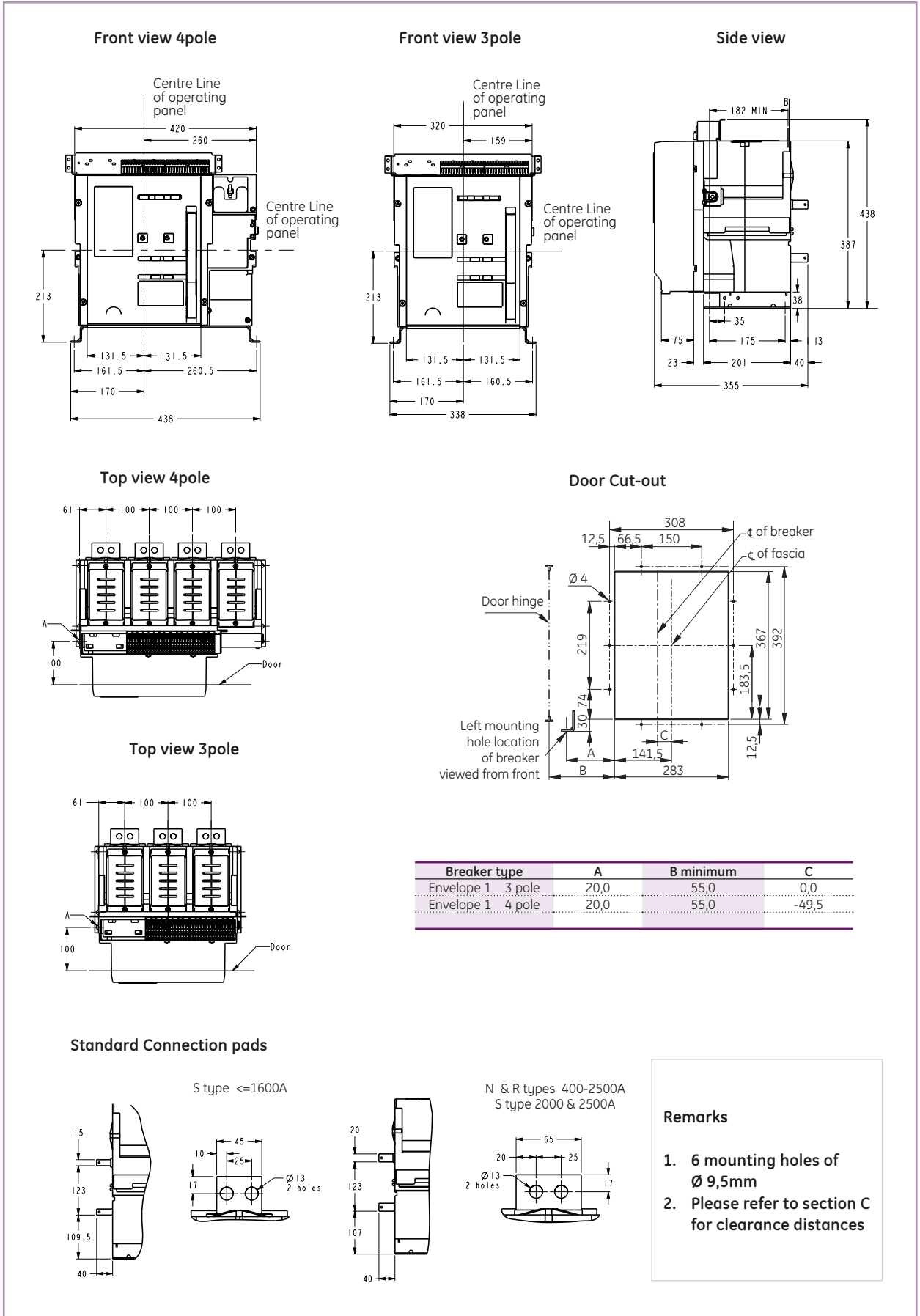

Envelope 1 - Draw-out Pattern: Universal connection pads

Envelope 1

Intro

A

B

C

D

E

X

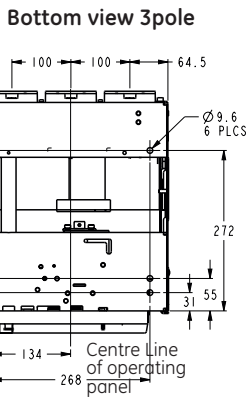
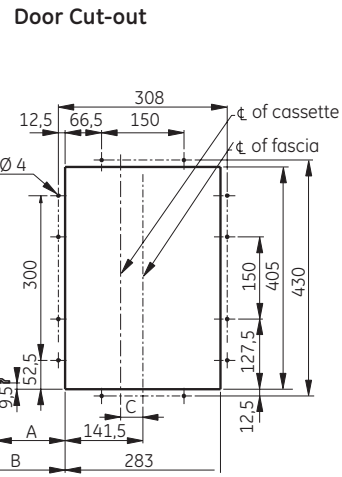
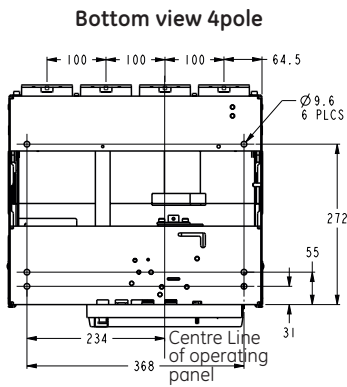
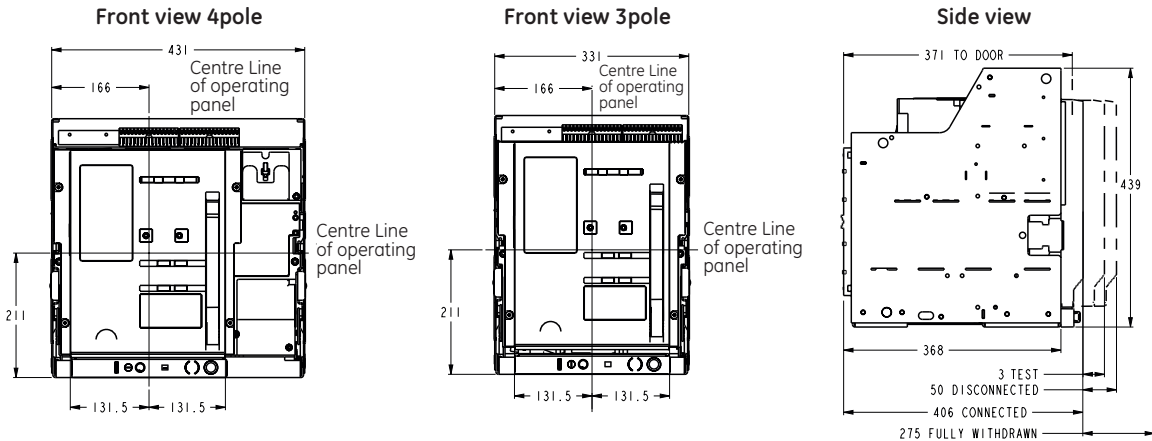

Breaker type	A	B minimum	C
Envelope 1 3 pole	-7.0	60.0	0.0
Envelope 1 4 pole	-7.0	60.0	-49.5

**Remarks**

- 6 mounting holes of Ø 9,5mm
- Please refer to section C for clearance distances

Universal Connection pads Mounted Horizontally or Vertically

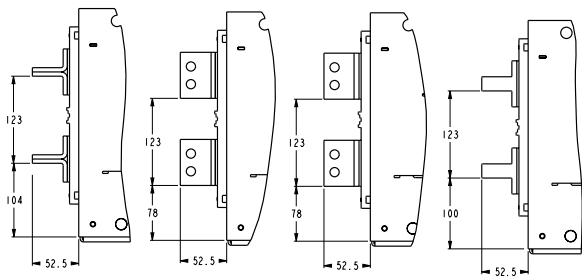

S type <=1600A

N types 400-2500A  
 S type 2000 & 2500A

Universal Connection pads Details

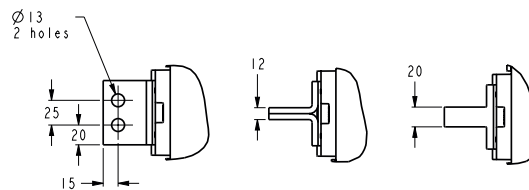

Valid for All types

S type <=1600A

N & R types 400-2500A  
 S type 2000 & 2500A



## Envelope 1 - Draw-out Pattern: Horizontal connection pads, applicable up to 2000A

Dimensional drawings

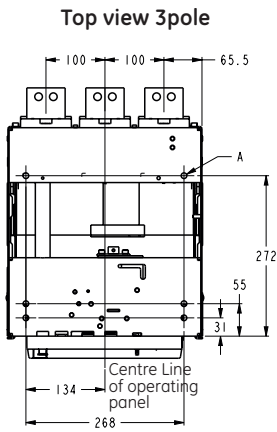
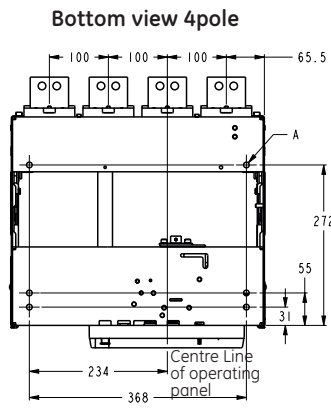
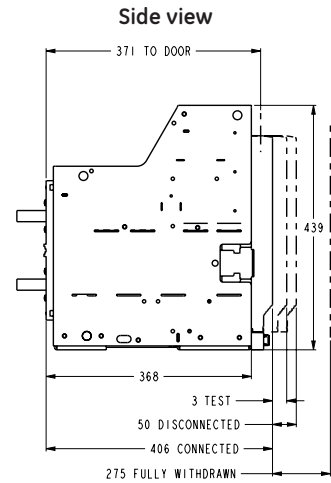
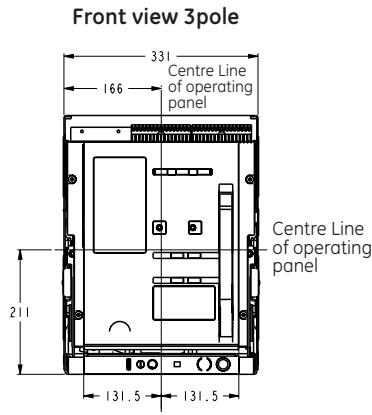
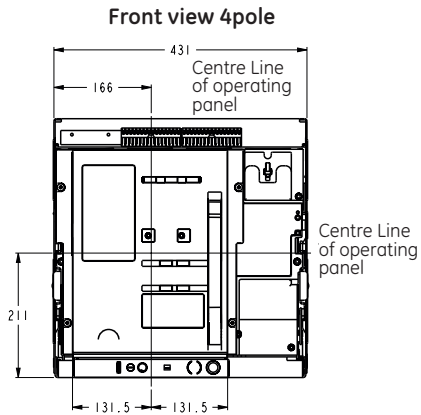

### Door Cut-out

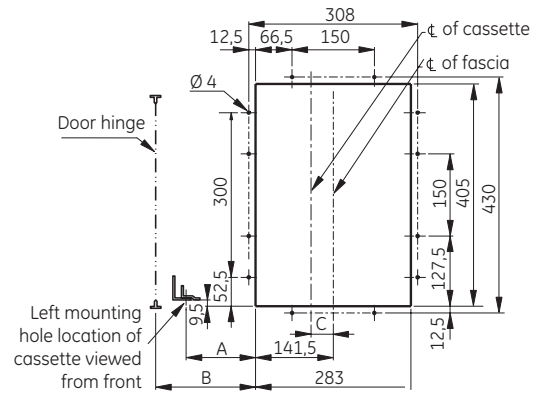

Breaker type	A	B minimum	C
Envelope 1 3 pole	-7,0	60,0	0,0
Envelope 1 4 pole	-7,0	60,0	-49,5

### Remarks

- 6 mounting holes of  $\varnothing 9,5\text{mm}$
- Please refer to section C for clearance distances

### Universal Connection pads Mounted Horizontally or Vertically

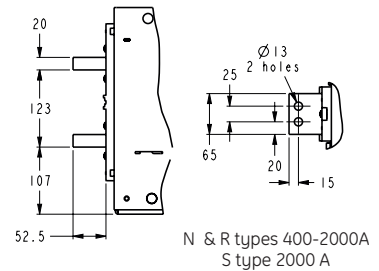
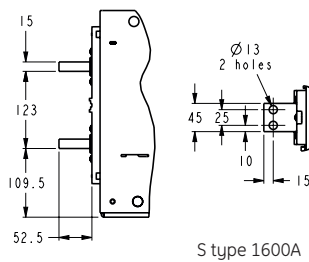
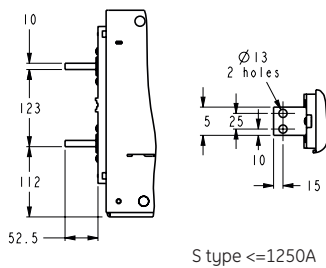

Envelope 2 - Fixed Pattern

Front view 4pole

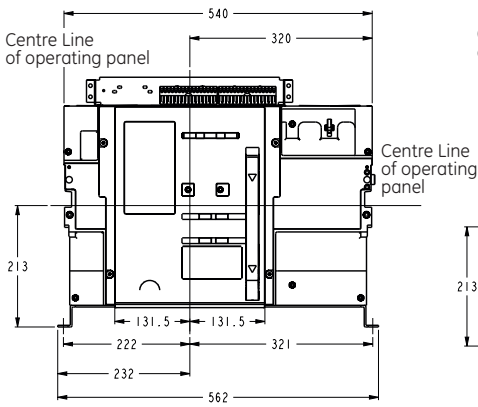

Front view 3pole

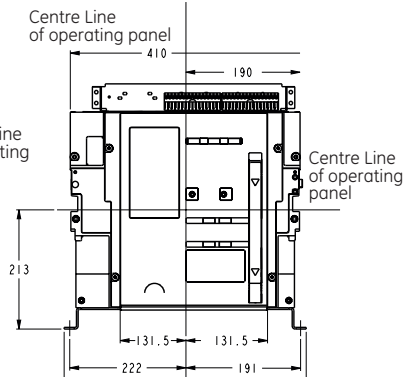

Side view

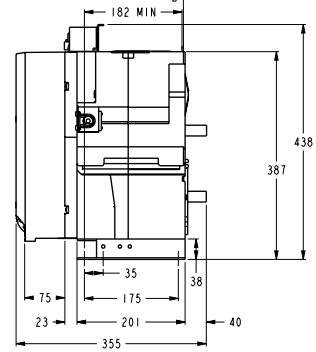

Top view 4pole

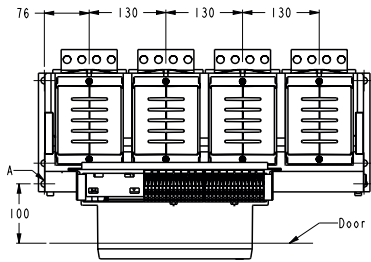

Door Cut-out

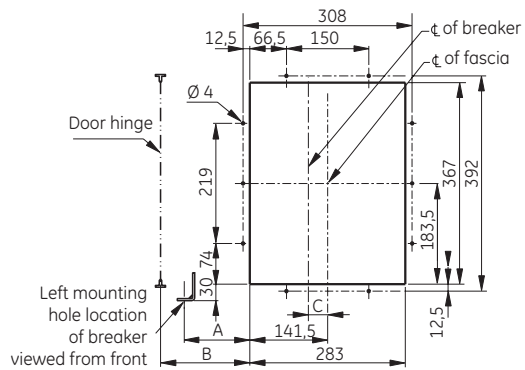

Top view 3pole

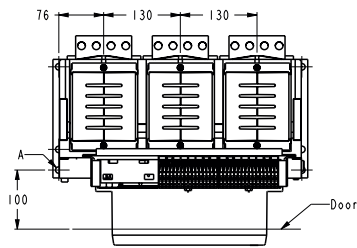

Breaker type	A	B minimum	C
Envelope 2 3 pole	80,0	115,0	15,5
Envelope 2 4 pole	80,0	115,0	-49,5

Standard Connection pads

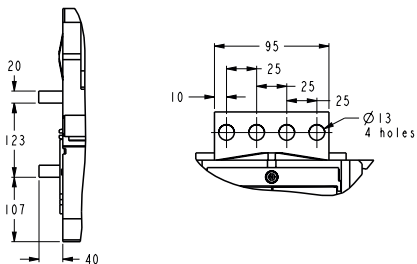

Remarks

- 6 mounting holes of  $\varnothing 9,5\text{mm}$
- Please refer to section C for clearance distances

## Envelope 2 - Draw-out Pattern: Universal connection pads

Dimensional drawings

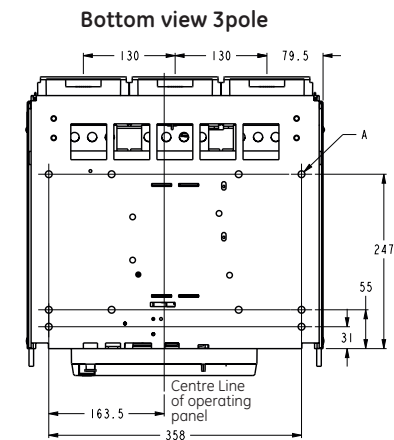
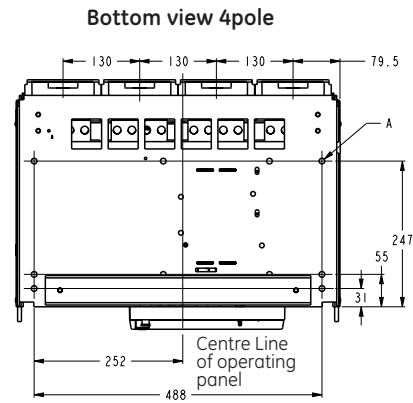
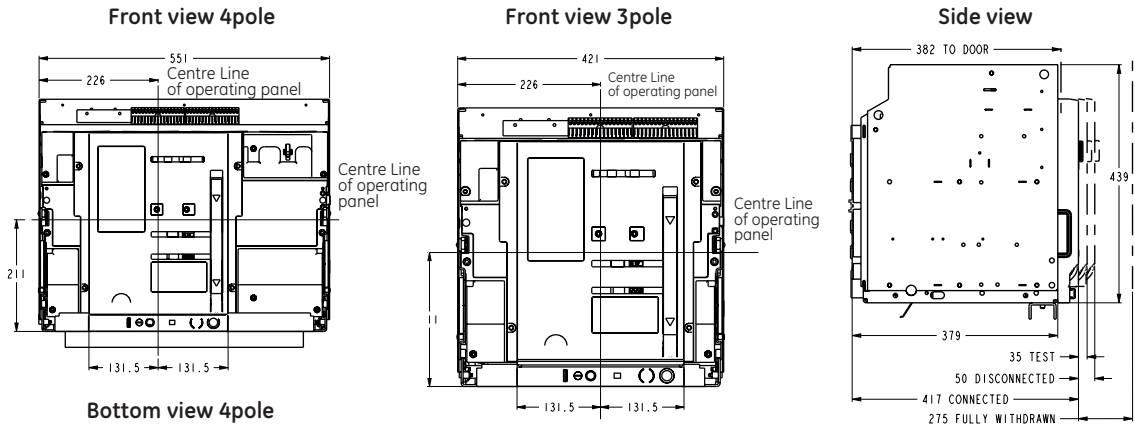

### Door Cut-out

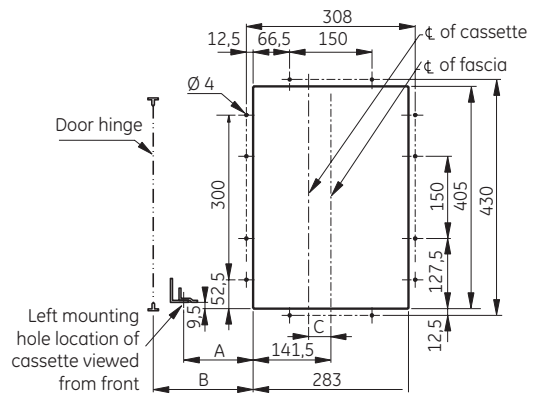

Breaker type	A	B minimum	C
Envelope 2 3 pole	53,0	125,0	15,5
Envelope 2 4 pole	53,0	125,0	-49,5

### Universal Connection pads Vertical or Horizontal max. 3200A

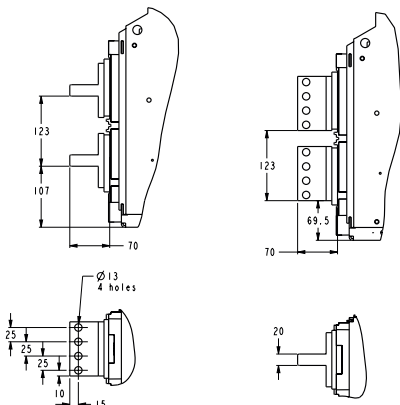

### Vertical Connection pads 4000A rating

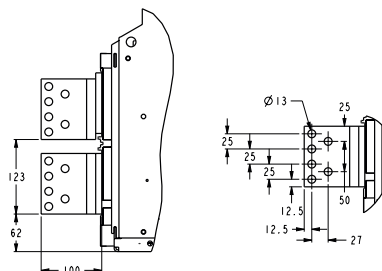

### Remarks

- 6 mounting holes of  $\varnothing 9,5\text{mm}$
- Please refer to section C for clearance distances



Envelope 2 - Draw-out Pattern: Horizontal connection pads, applicable upto 3200A

Envelope 2

Intro

A

B

C

D

E

X

Front view 4pole

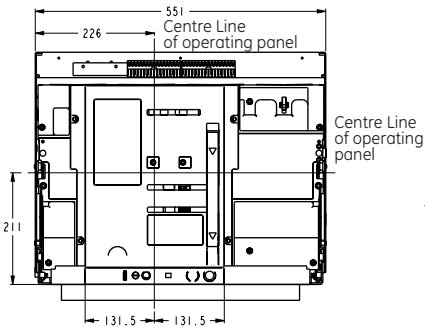

Front view 3pole

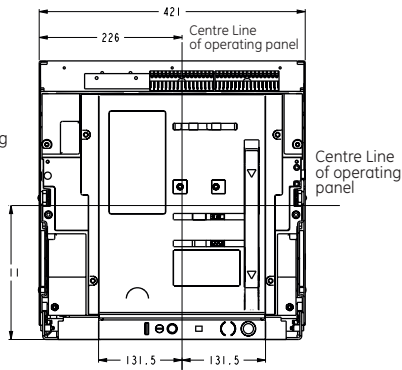

Side view

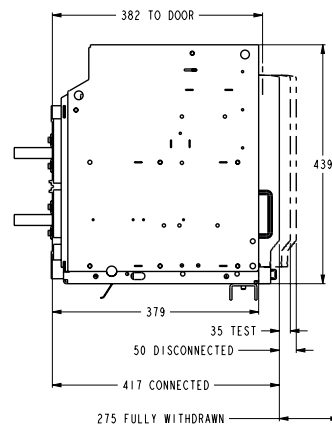

Bottom view 4pole

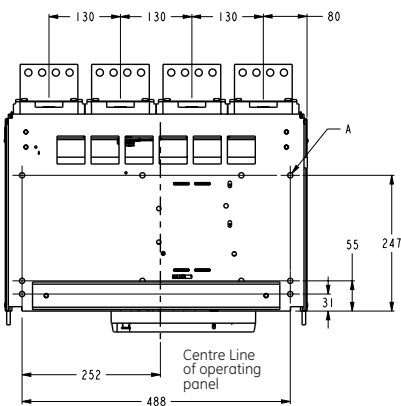

Door Cut-out

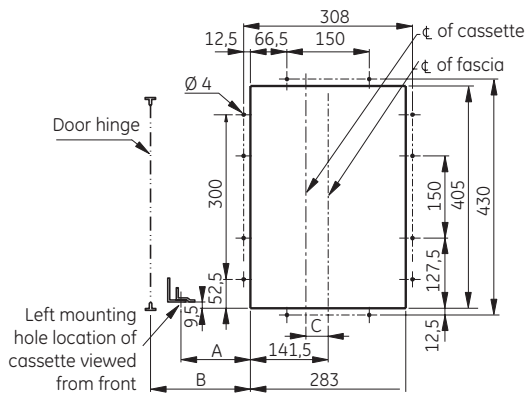

Bottom view 3pole

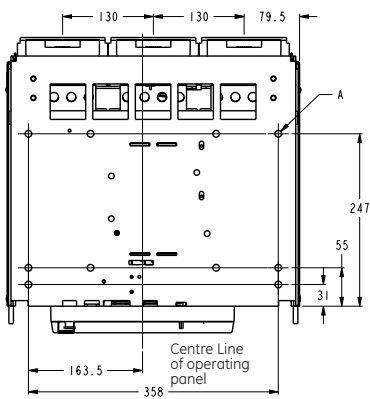

Breaker type	A	B minimum	C
Envelope 2 - 3 pole	53,0	125,0	15,5
Envelope 2 - 4 pole	53,0	125,0	-49,5

Connection pads details

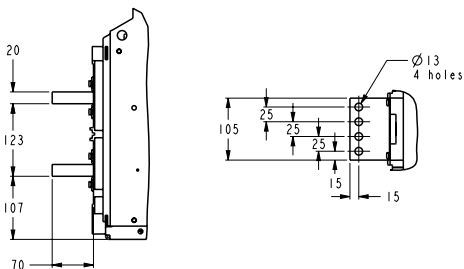

Remarks

1. 6 mounting holes of  $\varnothing 9,5\text{mm}$
2. Please refer to section C for clearance distances



## Envelope 1 & 2 - Alternate Connection Modes

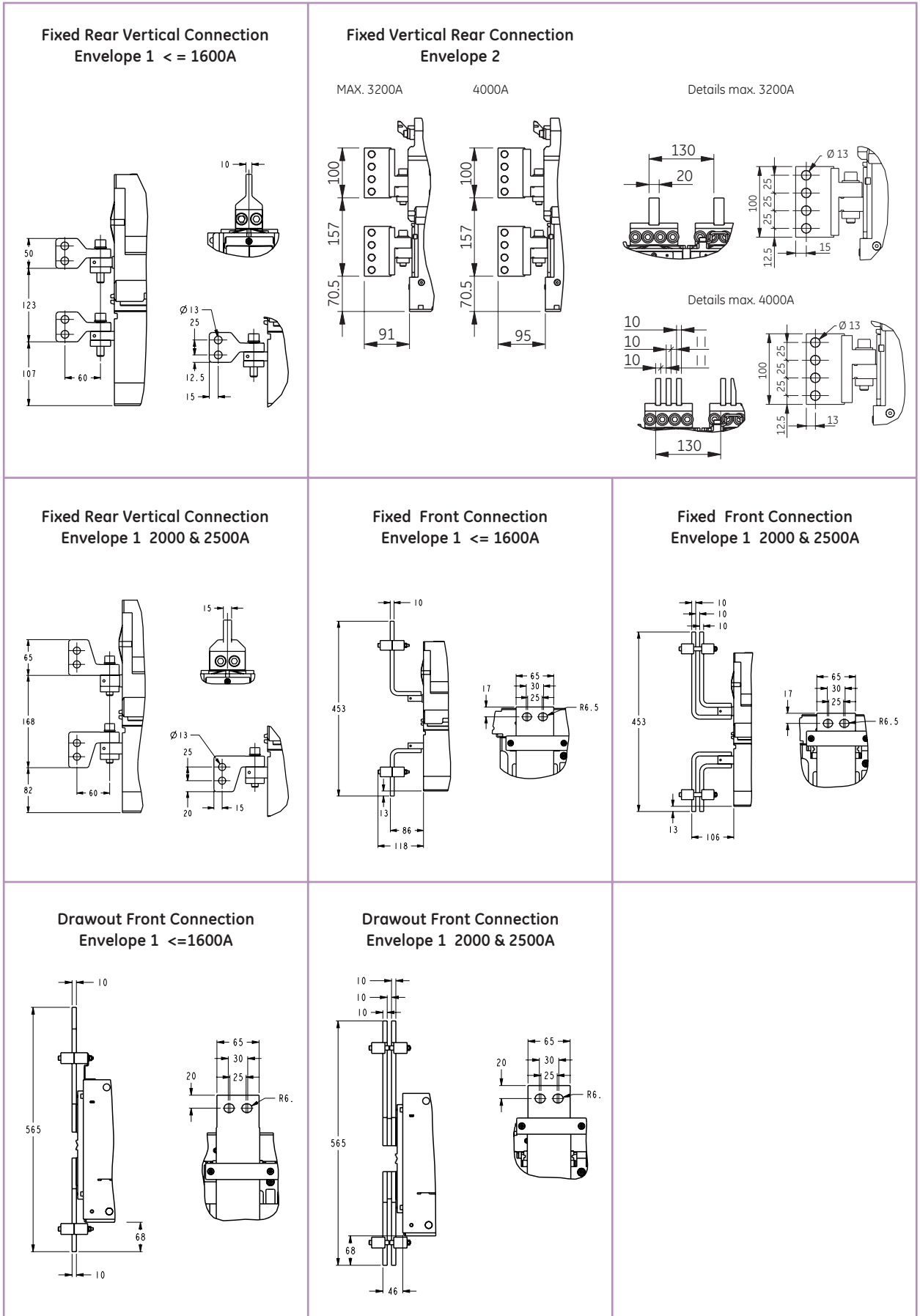

Intro

A

B

C

D

E

X





**IP54 Flange, Time Delay Module UVR, 24V Power Supply**

IP54 Flange

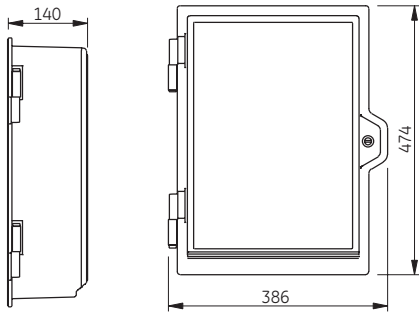

IP54 Flange drilling

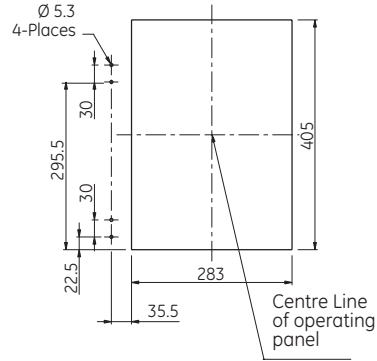

Time delay Module (UVR)

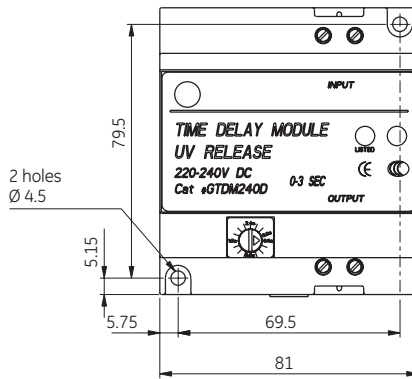
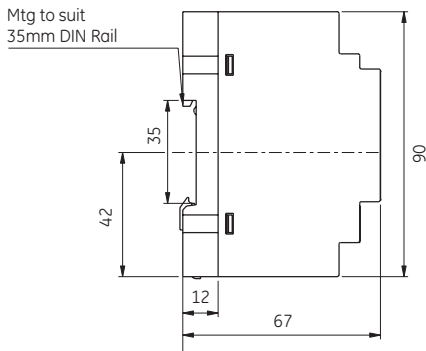

External 24V DC power supply

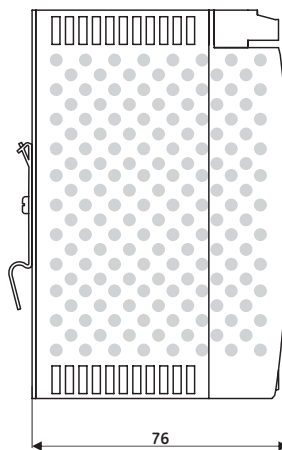
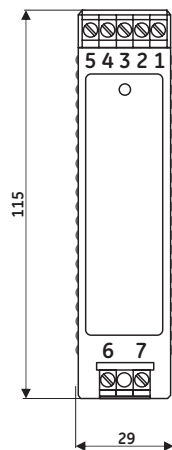

## Rogowski's & Door Interlock systems

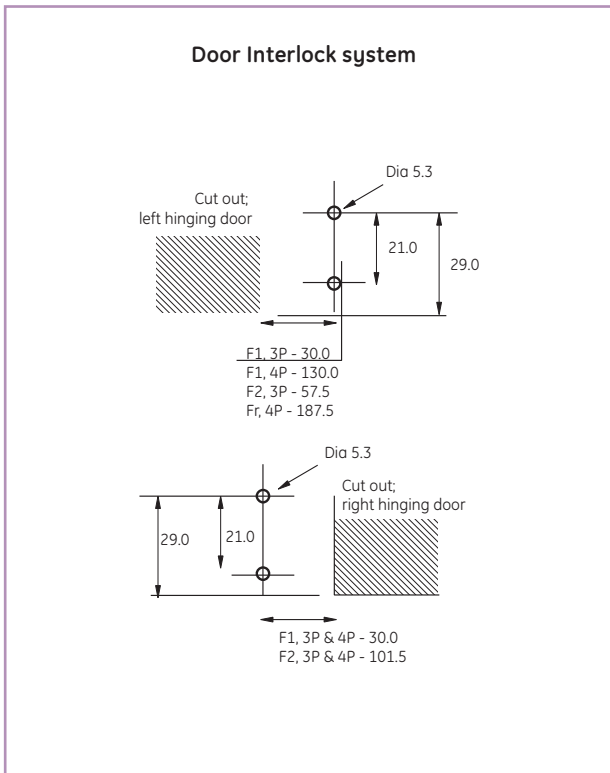
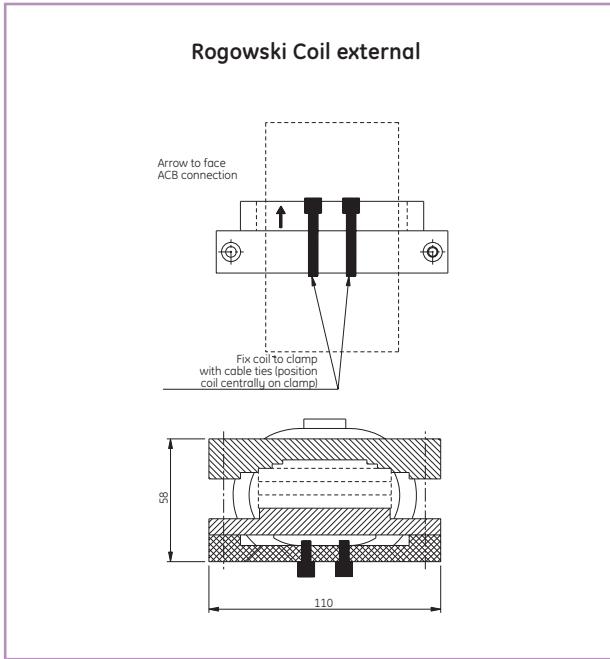

## Interlocking with Cable systems; 2 way

Fixed pattern 2-way cable interlock / Fixed pattern - Front/rear access

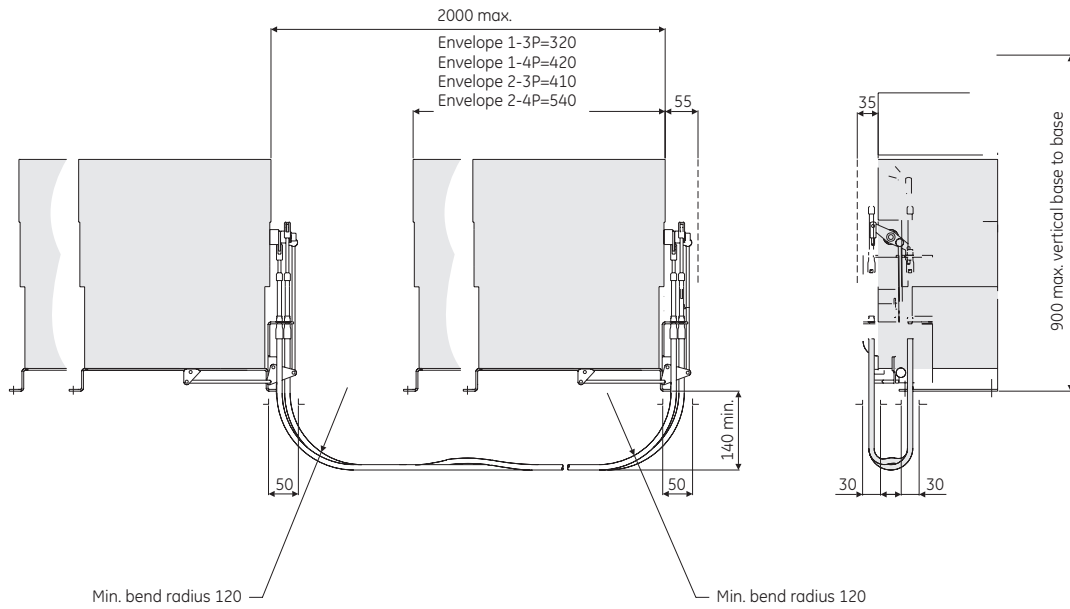

Draw-out 2-way cable interlock / Withdrawable pattern - Front/rear access

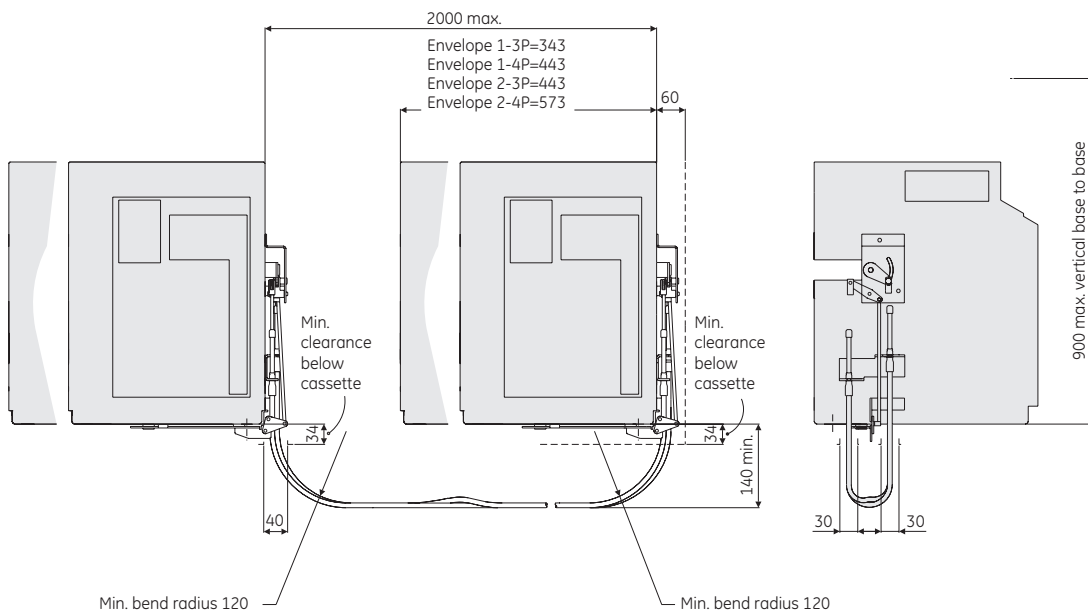

## Interlocking with Cable systems; 3 way

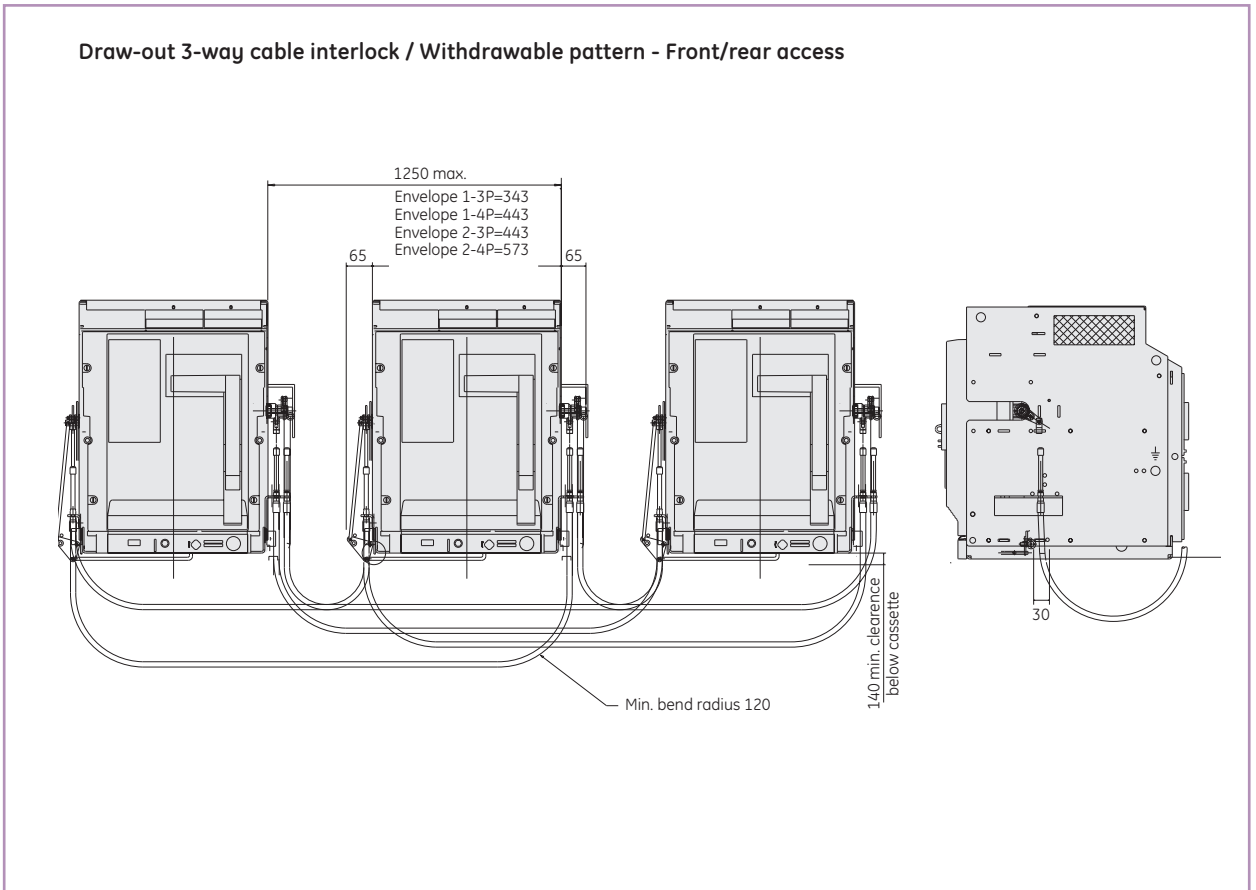
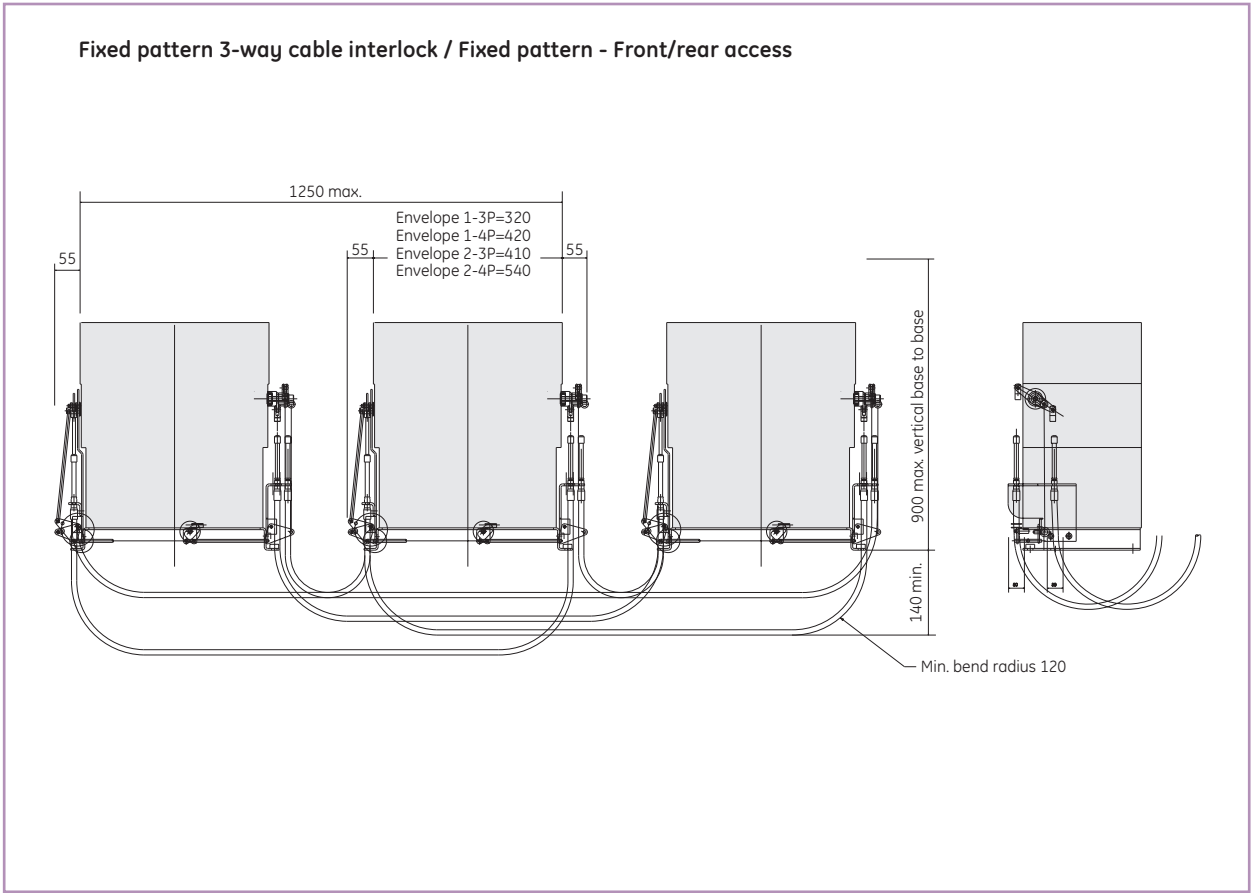

Air Circuit Breakers

Intro

Order Codes

A

Electronic Trip Units

B

Breaker Accessories

C

Application Guide

D

Dimensions

E

Numerical index

X

X.2 Numerical index by **reference number**

X.4 Numerical index by **catalogue number**



Ref. No.	Cat. No.	Page	Ref. No.	Cat. No.	Page	Ref. No.	Cat. No.	Page	Ref. No.	Cat. No.	Page
407700	GM01024D	A.9	444035	LG08S3	A.4	444162	LJ07R4	A.6	444305	LG13S5HR	A.12
407701	GM01024DR	A.11	444036	LG10S3	A.4	444163	LJ08R4	A.6	444306	LG16S2FR	A.12
407706	GM01110D	A.9	444037	LG13S3	A.4	444164	LJ10R4	A.6	444307	LG16N2UR	A.12
407707	GM01110DR	A.11	444038	LG16S3	A.4	444165	LJ13R4	A.6	444308	LG16S2HR	A.12
407712	GM01120A	A.9	444039	LG20S3	A.4	444166	LJ16R4	A.6	444309	LG16S5FR	A.12
407713	GM01120AR	A.11	444040	LG25S3	A.4	444167	LJ20R4	A.6	444310	LG16N5UR	A.12
407714	GM01240A	A.9	444041	LG20C3	A.4	444168	LJ25R4	A.6	444311	LG16S5HR	A.12
407715	GM01240AR	A.11	444042	LG25C3	A.4	444169	LJ20C4	A.6	444312	LG25N2FR	A.12
407720	GM01220D	A.9	444043	LG32C3	A.4	444170	LJ25C4	A.6	444313	LG25N2UR	A.12
407721	GM01220DR	A.11	444044	LG40C3	A.4	444171	LJ32C4	A.6	444314	LG20N2HR	A.12
407770	GSTR024D	A.9	444045	LG04N3	A.4	444172	LJ40C4	A.6	444315	LG25N5FR	A.12
407771	GSTR024DR	A.11	444046	LG07N3	A.4	444173	LJ04R6	A.6	444316	LG25N5UR	A.12
407772	GSTR048	A.9	444047	LG08N3	A.4	444174	LJ07R6	A.6	444317	LG20N5HR	A.12
407773	GSTR048R	A.11	444048	LG10N3	A.4	444175	LJ08R6	A.6	444318	LG32D2UR	A.12
407776	GSTR120	A.9	444049	LG13N3	A.4	444176	LJ10R6	A.6	444319	LG32D2HR	A.12
407777	GSTR120R	A.11	444050	LG16N3	A.4	444177	LJ13R6	A.6	444320	LG32D5UR	A.12
407778	GSTR240	A.9	444051	LG20N3	A.4	444178	LJ16R6	A.6	444321	LG32D5HR	A.12
407779	GSTR240R	A.11	444052	LG25N3	A.4	444179	LJ20R6	A.6	444322	LG40D2VR	A.12
407782	GSTR400A	A.9	444053	LG20D3	A.4	444180	LJ25R6	A.6	444323	LG40D5VR	A.12
407783	GSTR400AR	A.11	444054	LG25D3	A.4	444181	LJ20C6	A.6	444404	L25DARC	A.14
407795	GUVT024D	A.9	444055	LG32D3	A.4	444182	LJ25C6	A.6	444405	L13NCLS	A.14
407796	GSTR024DR	A.11	444056	LG40D3	A.4	444183	LJ32C6	A.6	444406	L16NCLS	A.14
407797	GUVT048	A.9	444066	LG04S4	A.4	444184	LJ40C6	A.6	444407	L25NCHT	A.14
407798	GSTR048R	A.11	444067	LG07S4	A.4	444190	LM01024D	A.9	444408	L25NCLS	A.14
407801	GUVT120	A.9	444068	LG08S4	A.4	444191	LM01110D	A.9	444409	L40DCLS	A.14
407802	GSTR120R	A.11	444069	LG10S4	A.4	444192	LM01220D	A.9	444410	L40DARC	A.14
407803	GUVT240	A.9	444070	LG13S4	A.4	444193	LM01120A	A.9	444411	L40DCHT	A.14
407804	GSTR240R	A.11	444071	LG16S4	A.4	444194	LM01240A	A.9	444412	LRHN	A.14
407807	GUVT400A	A.9	444072	LG20S4	A.4	444195	LM01024DR	A.11	444413	LFAL1	A.14
407808	GSTR400AR	A.11	444073	LG25S4	A.4	444196	LM01110DR	A.11	444414	LFAL2	A.14
407818	GTDM120A	A.13	444074	LG20C4	A.4	444197	LM01220DR	A.11	444415	LSDT	A.14
407819	GTDM120D	A.13	444075	LG25C4	A.4	444198	LM01120AR	A.11	444420	L104NRC	A.8
407820	GTDM240A	A.13	444076	LG32C4	A.4	444199	LM01240AR	A.11	444421	L106NRC	A.8
407821	GTDM240D	A.13	444077	LG40C4	A.4	444200	LDPRF	A.14	444422	L108NRC	A.8
407824	GTDM400A	A.13	444078	LG04N4	A.4	444205	LAS3	A.9	444423	L110NRC	A.8
407860	GCCN024DR	A.11	444079	LG07N4	A.4	444206	LAS4	A.9	444424	L113NRC	A.8
407861	GCCN024D	A.9	444080	LG08N4	A.4	444207	LBAT1	A.9	444425	L116NRC	A.8
407866	GCCN120R	A.11	444081	LG10N4	A.4	444208	LAS3R	A.11	444426	L120NRC	A.8
407867	GCCN120	A.9	444082	LG13N4	A.4	444209	LAS4R	A.11	444427	L220NRC	A.8
407868	GCCN240R	A.11	444083	LG16N4	A.4	444210	LBAT1R	A.11	444428	L225NRC	A.8
407869	GCCN240	A.9	444084	LG20N4	A.4	444211	LBPRO	A.9	444429	L229NRC	A.8
407897	GRTC1	A.9	444085	LG25N4	A.4	444212	LBRON	A.9	444430	L232NRC	A.8
407985	GRON	A.11	444086	LG20D4	A.4	444214	LBCA9	A.9	444432	L240NRC	A.8
407986	GPRO	A.11	444087	LG25D4	A.4	444215	LCPRO	A.9	444440	L16S4FFI	A.5
407990	GCB1	A.13	444088	LG32D4	A.4	444216	LCRON	A.9	444441	L16S4RVI	A.5
407991	GCB2	A.13	444089	LG40D4	A.4	444221	LI2FAD	A.10	444442	L16S6FFI	A.5
407992	GCB3	A.13	444100	LG04S6	A.4	444222	LI2WAD	A.10	444443	L16S6RVI	A.5
407993	GCB4	A.13	444101	LG07S6	A.4	444223	LI3FB	A.10	444444	L25N4FFI	A.5
407994	GCB5	A.13	444102	LG08S6	A.4	444224	LI3WB	A.10	444445	L25N4RVI	A.5
407995	GCB6	A.13	444103	LG10S6	A.4	444225	LI3FC	A.10	444446	L25N6FFI	A.5
407996	GCB7	A.13	444104	LG13S6	A.4	444226	LI3WC	A.10	444450	L1CTC1	A.12
407999	GTUTK20	A.13	444105	LG16S6	A.4	444227	LI3FDT	A.10	444451	L1CTC3	A.12
408026	GDPWR	A.14	444106	LG20S6	A.4	444228	LI3WDT	A.10	444452	L2CTC1	A.12
408033	GMCNR	A.11	444107	LG25S6	A.4	444230	LCPS1	A.9	444453	L2CTC3	A.12
408035	GMCN	A.9	444108	LG20C6	A.4	444231	LCPS1R	A.11	444465	SMS31F16L16S	A.15
408038	G54DR	A.14	444109	LG25C6	A.4	444232	LCPS2	A.9	444466	SMS41F16L16S	A.15
408040	GPBD	A.13	444110	LG32C6	A.4	444233	LCPS2R	A.11	444470	SMN31F16L16N	A.15
408045	GLB1	A.14	444111	LG40C6	A.4	444240	L1LHD	A.13	444471	SMN41F16L16N	A.15
408046	GTUS	A.13	444112	LG04N6	A.4	444241	L1RHD	A.13	444475	SMN31F25L25N	A.15
408047	GUNI	A.14	444113	LG07N6	A.4	444242	L2LHD	A.13	444476	SMN41F25L25N	A.15
408066	G32M4FFI	A.5	444114	LG08N6	A.4	444243	L2RHD	A.13	444480	SMS31W12L13S	A.15
408067	G40M4FFI	A.5	444115	LG10N6	A.4	444246	LREPM	A.13	444481	SMS41W12L13S	A.15
408068	G32M6FFI	A.5	444116	LG13N6	A.4	444260	LTG00K1XXSF	A.8	444485	SMS31F16L16S	A.15
408069	G40M6FFI	A.5	444117	LG16N6	A.4	444261	LTG00K2XXSF	A.8	444486	SMS41F16L16S	A.15
408070	G32M4RVI	A.5	444118	LG20N6	A.4	444262	LTG00K9XXSF	A.8	444490	SMN31W16L16N	A.15
408071	G32M6RVI	A.5	444119	LG25N6	A.4	444263	LTG00K3XXS	A.8	444491	SMN41W16L16N	A.15
408072	G40M4RVI	A.5	444120	LG20D6	A.4	444270	LG13S2FM	A.5	444495	SMN31W25L25N	A.15
408074	G40M6RVI	A.5	444121	LG25D6	A.4	444271	LG13S2UM	A.5	444496	SMN41W24L25N	A.15
408789	GAPU	A.13	444122	LG32D6	A.4	444272	LG13S2HM	A.5			
444000	LG04S1	A.4	444123	LG40D6	A.4	444273	LG13S5FM	A.5			
444001	LG07S1	A.4	444135	LJ04R1	A.6	444274	LG13S5UM	A.5			
444002	LG08S1	A.4	444136	LJ07R1	A.6	444275	LG13S5HM	A.5			
444003	LG10S1	A.4	444137	LJ08R1	A.6	444276	LG16S2FM	A.5			
444004	LG13S1	A.4	444138	LJ10R1	A.6	444277	LG16S2UM	A.5			
444005	LG16S1	A.4	444139	LJ13R1	A.6	444278	LG16S2HM	A.5			
444006	LG20S1	A.4	444140	LJ16R1	A.6	444279	LG16S5FM	A.5			
444007	LG25S1	A.4	444141	LJ20R1	A.6	444280	LG16S5UM	A.5			
444008	LG20C1	A.4	444142	LJ25R1	A.6	444281	LG16S5HM	A.5			
444009	LG25C1	A.4	444143	LJ20C1	A.6	444282	LG25N2FM	A.5			
444010	LG32C1	A.4	444144	LJ25C1	A.6	444283	LG25N2UM	A.5			
444011	LG40C1	A.4	444145	LJ32C1	A.6	444284	LG20N2HM	A.5			
444012	LG04N1	A.4	444146	LJ40C1	A.6	444285	LG25N5FM	A.5			
444013	LG07N1	A.4	444147	LJ04R3	A.6	444286	LG25N5UM	A.5			
444014	LG08N1	A.4	444148	LJ07R3	A.6	444287	LG20N5HM	A.5			
444015	LG10N1	A.4	444149	LJ08R3	A.6	444288	LG32D2UM	A.5			
444016	LG13N1	A.4	444150	LJ10R3	A.6	444289	LG32D2HM	A.5			
444017	LG16N1	A.4	444151	LJ13R3	A.6	444290	LG32D5UM	A.5			
444018	LG20N1	A.4	444152	LJ16R3	A.6	444291	LG32D5HM	A.5			
444019	LG25N1	A.4	444153	LJ20R3	A.6	444292	LG40D2VM	A.5			
444020	LG20D1	A.4	444154	LJ25R3	A.6	444293	LG40D5VM	A.5			
444021	LG25D1	A.4	444155	LJ20C3	A.6	444300	LG13S2FR	A.12			
444022	LG32D1	A.4	444156	LJ25C3	A.6	444301	LG13N2UR	A.12			
444023	LG40D1	A.4	444157	LJ32C3	A.6	444302	LG13S2HR	A.12			
444033	LG04S3	A.4	444158	LJ40C3	A.6	444303	LG13S5FR	A.12			
444034	LG07S3	A.4	444161	LJ04R4	A.6	444304	LG13N5UR	A.12			



Cat. No.	Ref. No.	Page	Cat. No.	Ref. No.	Page	Cat. No.	Ref. No.	Page	Cat. No.	Ref. No.	Page
G32M4FFI	408066	A.5	L2RHD	444243	A.13	LG20C4	444074	A.4	LJ13R4	444165	A.6
G32M4RVI	408070	A.5	L40DARC	444410	A.14	LG20C6	444108	A.4	LJ13R6	444177	A.6
G32M6FFI	408068	A.5	L40DCHT	444411	A.14	LG20D1	444020	A.4	LJ16R1	444140	A.6
G32M6RVI	408071	A.5	L40DCLS	444409	A.14	LG20D3	444053	A.4	LJ16R3	444152	A.6
G40M4FFI	408067	A.5	LAS3	444205	A.9	LG20D4	444086	A.4	LJ16R4	444166	A.6
G40M4RVI	408072	A.5	LAS3R	444208	A.11	LG20D6	444120	A.4	LJ16R6	444178	A.6
G40M6FFI	408069	A.5	LAS4	444206	A.9	LG20N1	444018	A.4	LJ20C1	444143	A.6
G40M6RVI	408074	A.5	LAS4R	444209	A.11	LG20N2HM	444284	A.5	LJ20C3	444155	A.6
G54DR	408038	A.14	LBAT1	444207	A.9	LG20N2HR	444314	A.12	LJ20C4	444169	A.6
GAPU	408789	A.13	LBAT1R	444210	A.11	LG20N3	444051	A.4	LJ20C6	444181	A.6
GCB1	407990	A.13	LBCA9	444214	A.9	LG20N4	444084	A.4	LJ20R1	444141	A.6
GCB2	407991	A.13	LBPRO	444211	A.9	LG20N5HM	444287	A.5	LJ20R3	444153	A.6
GCB3	407992	A.13	LBRON	444212	A.9	LG20N5HR	444317	A.12	LJ20R4	444167	A.6
GCB4	407993	A.13	LCPRO	444215	A.9	LG20N6	444118	A.4	LJ20R6	444179	A.6
GCB5	407994	A.13	LCPS1	444230	A.9	LG20S1	444006	A.4	LJ25C1	444144	A.6
GCB6	407995	A.13	LCPS1R	444231	A.11	LG20S3	444039	A.4	LJ25C3	444156	A.6
GCB7	407996	A.13	LCPS2	444232	A.9	LG20S4	444072	A.4	LJ25C4	444170	A.6
GCCN024D	407861	A.9	LCPS2R	444233	A.11	LG20S6	444106	A.4	LJ25C6	444182	A.6
GCCN024DR	407860	A.11	LCRON	444216	A.9	LG25C1	444009	A.4	LJ25R1	444142	A.6
GCCN120	407867	A.9	LDPRF	444200	A.14	LG25C3	444042	A.4	LJ25R3	444154	A.6
GCCN120R	407866	A.11	LFAL1	444413	A.14	LG25C4	444075	A.4	LJ25R4	444168	A.6
GCCN240	407869	A.9	LFAL2	444414	A.14	LG25C6	444109	A.4	LJ25R6	444180	A.6
GCCN240R	407868	A.11	LG04N1	444012	A.4	LG25D1	444021	A.4	LJ32C1	444145	A.6
GDPRW	408026	A.14	LG04N3	444045	A.4	LG25D3	444054	A.4	LJ32C3	444157	A.6
GLB1	408045	A.14	LG04N4	444078	A.4	LG25D4	444087	A.4	LJ32C4	444171	A.6
GM01024D	407700	A.9	LG04N6	444112	A.4	LG25D6	444121	A.4	LJ32C6	444183	A.6
GM01024DR	407701	A.11	LG04S1	444000	A.4	LG25N1	444019	A.4	LJ40C1	444146	A.6
GM01110D	407706	A.9	LG04S3	444033	A.4	LG25N2FM	444282	A.5	LJ40C3	444158	A.6
GM01110DR	407707	A.11	LG04S4	444066	A.4	LG25N2FR	444312	A.12	LJ40C4	444172	A.6
GM01120A	407712	A.9	LG04S6	444100	A.4	LG25N2UM	444283	A.5	LJ40C6	444184	A.6
GM01120AR	407713	A.11	LG07N1	444013	A.4	LG25N3	444052	A.4	LM01024D	444190	A.9
GM01220D	407720	A.9	LG07N3	444046	A.4	LG25N4	444085	A.4	LM01024DR	444195	A.11
GM01220DR	407721	A.11	LG07N4	444079	A.4	LG25N5FM	444285	A.5	LM01110D	444191	A.9
GM01240A	407714	A.9	LG07N6	444113	A.4	LG25N5FR	444315	A.12	LM01110DR	444196	A.11
GM01240AR	407715	A.11	LG07S1	444001	A.4	LG25N5UM	444286	A.5	LM01120A	444193	A.9
GMCN	408035	A.9	LG07S3	444034	A.4	LG25N2UR	444313	A.12	LM0120AR	444198	A.11
GMCNR	408033	A.11	LG07S4	444067	A.4	LG25N5UR	444316	A.12	LM01220D	444192	A.9
GPBD	408040	A.13	LG07S6	444101	A.4	LG25N6	444119	A.4	LM01220DR	444197	A.11
GPRO	407986	A.11	LG08N1	444014	A.4	LG25S1	444007	A.4	LM01240A	444194	A.9
GRON	407985	A.11	LG08N3	444047	A.4	LG25S3	444040	A.4	LM01240AR	444199	A.11
GRTC1	407897	A.9	LG08N4	444080	A.4	LG25S4	444073	A.4	LREPM	444246	A.13
GSTR024D	407770	A.9	LG08N6	444114	A.4	LG25S6	444107	A.4	LRHN	444412	A.14
GSTR024DR	407796	A.11	LG08S1	444002	A.4	LG32C1	444010	A.4	LSDT	444415	A.14
GSTR048	407772	A.9	LG08S3	444035	A.4	LG32C3	444043	A.4	LTG00K1XXSF	444260	A.8
GSTR048R	407798	A.11	LG08S4	444068	A.4	LG32C4	444076	A.4	LTG00K2XXSF	444261	A.8
GSTR120	407776	A.9	LG08S6	444102	A.4	LG32C6	444110	A.4	LTG00K3XXS	444263	A.8
GSTR120R	407802	A.11	LG10N1	444015	A.4	LG32D1	444022	A.4	LTG00K9XXSF	444262	A.8
GSTR240	407778	A.9	LG10N3	444048	A.4	LG32D2HM	444289	A.5	SMN31F16L16N	444470	A.15
GSTR240R	407804	A.11	LG10N4	444081	A.4	LG32D2HR	444319	A.12	SMN31F25L25N	444475	A.15
GSTR400A	407782	A.9	LG10N6	444115	A.4	LG32D2UM	444288	A.5	SMN31W16L16N	444490	A.15
GSTR400AR	407808	A.11	LG10S1	444003	A.4	LG32D2UR	444318	A.12	SMN31W25L25N	444495	A.15
GTDN120A	407818	A.13	LG10S3	444036	A.4	LG32D3	444055	A.4	SMN41F16L16N	444471	A.15
GTDN120D	407819	A.13	LG10S4	444069	A.4	LG32D4	444088	A.4	SMN41F25L25N	444476	A.15
GTDN240A	407820	A.13	LG10S6	444103	A.4	LG32D5HM	444291	A.5	SMN41W16L16N	444491	A.15
GTDN240D	407821	A.13	LG13N1	444016	A.4	LG32D5HR	444321	A.12	SMN41W24L25N	444496	A.15
GTDN400A	407824	A.13	LG13N2UR	444301	A.12	LG32D5UM	444290	A.5	SMS31F16L16S	444465	A.15
GTUS	408046	A.13	LG13N3	444049	A.4	LG32D5UR	444320	A.12	SMS31W12L13S	444480	A.15
GTUTK20	407999	A.13	LG13N4	444082	A.4	LG32D6	444122	A.4	SMS41F16L16S	444466	A.15
GUNI	408047	A.14	LG13N5UR	444304	A.12	LG40C1	444011	A.4	SMS41W12L13S	444481	A.15
GUVT024D	407795	A.9	LG13N6	444116	A.4	LG40C3	444044	A.4			
GUVT048	407797	A.9	LG13S1	444004	A.4	LG40C4	444077	A.4			
GUVT120	407801	A.9	LG13S2FM	444270	A.5	LG40C6	444111	A.4			
GUVT240	407803	A.9	LG13S2FR	444300	A.12	LG40D1	444023	A.4			
GUVT400A	407807	A.9	LG13S2HM	444272	A.5	LG40D2VM	444292	A.5			
L104NRC	444420	A.8	LG13S2HR	444302	A.12	LG40D2VR	444322	A.12			
L106NRC	444421	A.8	LG13S2UM	444271	A.5	LG40D3	444056	A.4			
L108NRC	444422	A.8	LG13S3	444037	A.4	LG40D4	444089	A.4			
L110NRC	444423	A.8	LG13S4	444070	A.4	LG40D5VM	444293	A.5			
L113NRC	444424	A.8	LG13S5FM	444273	A.5	LG40D5VR	444323	A.12			
L116NRC	444425	A.8	LG13S5FR	444303	A.12	LG40D6	444123	A.4			
L120NRC	444426	A.8	LG13S5HM	444275	A.5	LI2FAD	444221	A.10			
L125NRC	444428	A.8	LG13S5HR	444305	A.12	LI2WAD	444222	A.10			
L13NCLS	444405	A.14	LG13S5UM	444274	A.5	LI3FB	444223	A.10			
L16NCLS	444406	A.14	LG13S6	444104	A.4	LI3FC	444225	A.10			
L16S4FFI	444440	A.5	LG16N1	444017	A.4	LI3FDT	444227	A.10			
L16S4RVI	444441	A.5	LG16N2UR	444307	A.12	LI3WB	444224	A.10			
L16S6FFI	444442	A.5	LG16N3	444050	A.4	LI3WC	444226	A.10			
L16S6RVI	444443	A.5	LG16N4	444083	A.4	LI3WDT	444228	A.10			
L1CTC1	444450	A.12	LG16N5UR	444310	A.12	LJ04R1	444135	A.6			
L1CTC3	444451	A.12	LG16N6	444117	A.4	LJ04R3	444147	A.6			
L1LHD	444240	A.13	LG16S1	444005	A.4	LJ04R4	444161	A.6			
L1RHD	444241	A.13	LG16S2FM	444276	A.5	LJ04R6	444173	A.6			
L220NRC	444427	A.8	LG16S2FR	444306	A.12	LJ07R1	444136	A.6			
L225NRC	444429	A.8	LG16S2HM	444278	A.5	LJ07R3	444148	A.6			
L232NRC	444430	A.8	LG16S2HR	444308	A.12	LJ07R4	444162	A.6			
L240NRC	444432	A.8	LG16S2UM	444277	A.5	LJ07R6	444174	A.6			
L25DARC	444404	A.14	LG16S3	444038	A.4	LJ08R1	444137	A.6			
L25N4FFI	444444	A.5	LG16S4	444071	A.4	LJ08R3	444149	A.6			
L25N4RVI	444445	A.5	LG16S5FM	444279	A.5	LJ08R4	444163	A.6			
L25N6FFI	444446	A.5	LG16S5FR	444309	A.12	LJ08R6	444175	A.6			
L25N6RVI	444446	A.5	LG16S5HM	444281	A.5	LJ10R1	444138	A.6			
L25NCHT	444407	A.14	LG16S5HR	444311	A.12	LJ10R3	444150	A.6			
L25NCLS	444408	A.14	LG16S5UM	444280	A.5	LJ10R4	444164	A.6			
L2CTC1	444452	A.12	LG16S6	444105	A.4	LJ10R6	444176	A.6			
L2CTC3	444453	A.12	LG20C1	444008	A.4	LJ13R1	444139	A.6			
L2LHD	444242	A.13	LG20C3	444041	A.4	LJ13R3	444151	A.6			

